

GESTRA Steam Systems

Product Range B1

Oil & Turbidity Detector TURBISCOPE OR 52-7

OR 52-7

Description

The GESTRA Turbiscopes OR 52-7 is designed for the continuous monitoring and detection of oil contamination of water and used in conjunction with oily water separators as 15 ppm bilge alarm.

The equipment meets the requirements of the International Maritime Organization (IMO) for bilge alarm monitors, MEPC. 107 (49).

The oil & turbidity detector OR 52-7 can be used:

- On board of marine vessels for monitoring the oily water separating equipment for bilge water according to IMO Resolution MEPC. 107 (49) as 15 ppm oil content alarm.

Design

The oil & turbidity detector OR 52-7 consists of the measuring sensor ORG 12 and the measuring transducer ORT 7.

Measuring sensor ORG 12

The measuring sensor is a photometric measuring device consisting of a light source (light emitter) and a light receiver fitted with two photosensitive elements. A sightglass with integrated glass cylinder is mounted between the light emitter and the light receiver. The sensor is provided with two connections for the liquid to be monitored (with flow reversal) and one connection for the rinsing water. It is possible to clean the inside of the glass cylinder during operation with the aid of the cleaning plunger.

Measuring transducer ORT 7

The measuring transducer ORT 7 is located in a field case for wall installation. The cover of the case is provided with the operating buttons, a LCD display and the LEDs for indicating the measured values, limits and error messages.

Function

The oil & turbidity detector OR 52-7 is an industrial instrument for detecting suspensions of solids in clear liquids and oil contamination in water.

The constant light beam generated in the measuring sensor passes through the transparent liquid. Any foreign matter which is not dissolved scatters the beam, with emulsified oils scattering the light mainly in the forward direction. The intensity of the scattered light is converted into an electric current and then used as measure of the degree of contamination.

The measuring transducer has the following functions:

- Control of the measuring sensor and signal evaluation
- Control of the purging valve
- Limit ALARM 1 and ALARM 2
- Analog actual value output 0/4 – 20 mA
- ALARM 2 indicates a malfunction in the turbidity sensor
- Indication of actual value / limits
- Storage and indication of alarm, malfunction and status messages
- Control of the bilge bypass via output ALARM 2

Technical Data

Measuring transducer ORG 12

Nominal size

DN 10, connection 3/8" to DIN ISO 228

Nominal pressure

PN 10

pH value

Up to 10.5 (a pH value of 11 and above will lead to wear of the glass, depending on the temperature!)

Fluid temperature range

0 – 60 °C with drying cartridge

Ambient temperature

Max. 60 °C

Materials

Housing cover: 0.6025 galvanised
Wetted parts: 0.6025 galvanised
Throttle: 1.4571
Screwed union: St
Glass cylinder: Duran 50
Internal seal: Silicone
Oil-seal rings: Perbunan
Housing: 0.6025 galvanised
Cleaning ring: EPDM

Light emitter *)

Glow lamp 12 V / 10 W BA 15s

Light receiver *)

Two silicon photoelectric cells

Purging valve *)

2/2 way solenoid valve

Directly controlled, normally closed

Connection: 3/8" ISO 228

Valve body: Brass

Internals: Ms 2.0401 / S. S. 1.4104

Internal seal: FKM

Solenoid: Voltage 24 V / 50 Hz, 43 / 24 VA

*) Electric connection via 4 m connecting cable fitted with four pole connector, protection IP 65, halogen-free cable, resistant to flame spread.

Weight

Approx. 6.8 kg

Measuring transducer ORT 7

Inputs / outputs

2 Photocells for inputs: directly transmitted light / scattered light,

1 Voltage output for light emitter, 1 – 12 V, pulse-amplitude modulated,

1 Signal input for separator ON/OFF,

1 GPS input RS 485, 4800 Baud, NMEA 183 protocol, data record GPRMC,

3 Volt-free change-over contacts for alarm 1, 2 and purging valve (Clw), contact material AgNi 0.15, max. contact rating for switching voltages 24 V AC/DC, 115 V AC and 230 V AC: resistive / inductive 4 A,

1 Current output 0/4 – 20 mA as actual value output, max. load 500 ohm.

Indicators and adjustors

1 LCD display for indicating the actual value, limits, status and malfunctions,

8 Membrane keys,

4 LEDs for indicating alarm, status and malfunction

3 Green LEDs on basic circuit board for monitoring the operating voltages

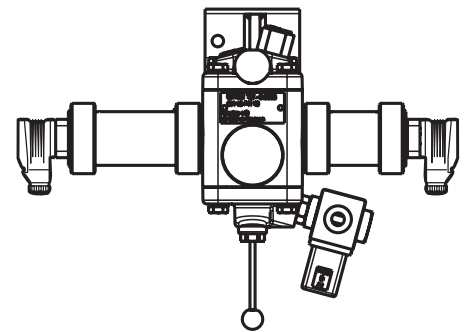

Measuring sensor ORG 12

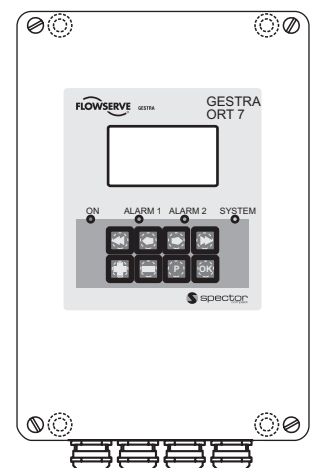

Measuring transducer ORT 7

Oil & Turbidity Detector TURBISCOPE OR 52-7

Technical Data – continued –

Measuring transducer ORT 7 – continued –

Data storage
DataFlashcard 8 MB

Measuring range
0 to 25 ppm (ppm = parts per million)

Actual value output
0 or 4 mA = 0 ppm, 20 mA = 25 ppm

Limits for alarm 1 and 2, adjustment range
Adjustable between 0 and 15 ppm

Delay of response for alarm 1 and 2, adjustment range
Adjustable between 0 and 15 sec.

Mains voltage
24 V +10 / -15 %, 50/60 Hz
230 V +10 / -15 %, 50/60 Hz (optional)
115 V +10 / -15 %, 50/60 Hz (optional)

Power consumption
50 VA

Fuse
24 V: Thermal fuse M 1.6 A 5 x 20,
230 V: Thermal fuse M 0.2 A 5 x 20
115 V: Thermal fuse M 0.4 A 5 x 20

Housing
Field case for wall mounting,
Case material: die-cast aluminium

Cable gland / Electrical connection
8 cable glands with integrated cable clamps, M 16 x 1.5
3 Three-pole screw-type terminal strips,
conductor size 0.75 mm²
8 Multi-pole screw-type terminal strips, detachable,
conductor size 1.5 mm²

Load
Up to 500 ohm

Protection
IP 65 to EN 60529

Admissible ambient temperature
0 – 55 °C

Weight
3.6 kg

Scope of supply

- 1 Measuring transducer ORT 7,
- Measuring sensor ORG 12 with solenoid valve,
drying cartridge (fitted)
- 1 Light emitter, supplied but not fitted
- 1 Kit of spare seals, supplied

Order and Enquiry Specification

GESTRA Oil & Turbidity Detector TURBISCOPE, consisting of a measuring sensor with ancillary equipment and a measuring transformer.

- GESTRA Oil and turbidity detector OR 52-7,
consisting of the measuring transducer ORG 12
(GG-25) and the measuring transducer ORT 7.

Mains voltage 24 V 50/60 Hz.

ATEX (Atmosphère Explosible)

According to the European Directive 94/9/EC the equipment must not be used in potentially explosive areas.

Supply in accordance with our general terms of business.

Dimensions

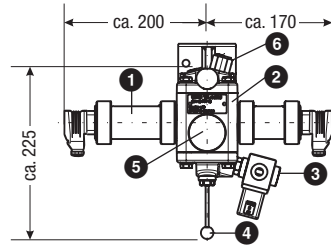

Measuring sensor ORG 12

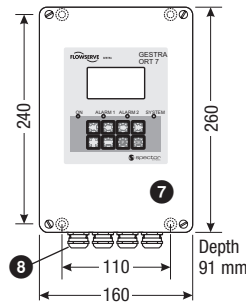

Measuring transducer ORT 7
(Field case for wall mounting)

Wiring Diagram OR 52-7

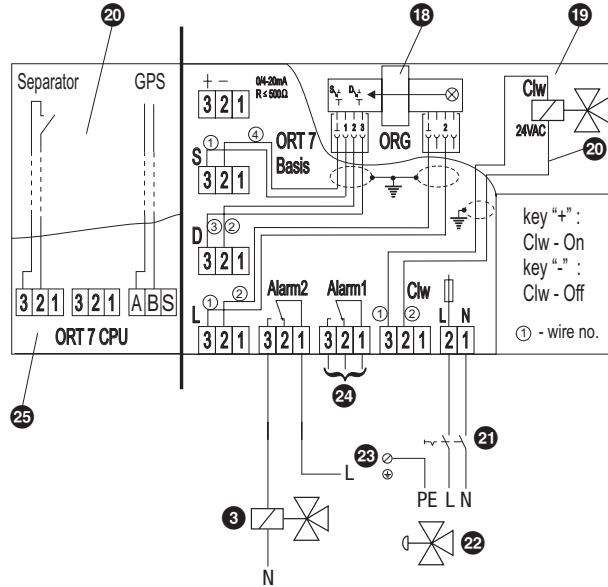

Key

- 1 Light emitter
- 2 Measuring cell
- 3 Solenoid valve Clw
- 4 Cleaning device
- 5 Drying cartridge
- 6 Throttle
- 7 Measuring transducer ORT 7
- 8 Cable glands
- 18 Measuring sensor
- 19 Purging valve
- 20 External wiring
- 21 Disconnecter
- 22 Three-way valve
- 23 Earthing screw in housing
- 24 To first alarm
- 25 Attached to the housing lid
- 26 Overboard discharge line
- 27 To bilge
- 28 Three-way valve
- 29 Fit vacuum breaker above the oil separator
- 30 10 x 1 mm copper or stainless steel tube
- 31 Outlet
- 32 Inlet
- 33 Pure water inlet (water pressure \geq 2.5 bar)
- 34 Outlet for separator
- 35 Separator
- 36 Pressure maintaining valve (if required)

Examples of Installation

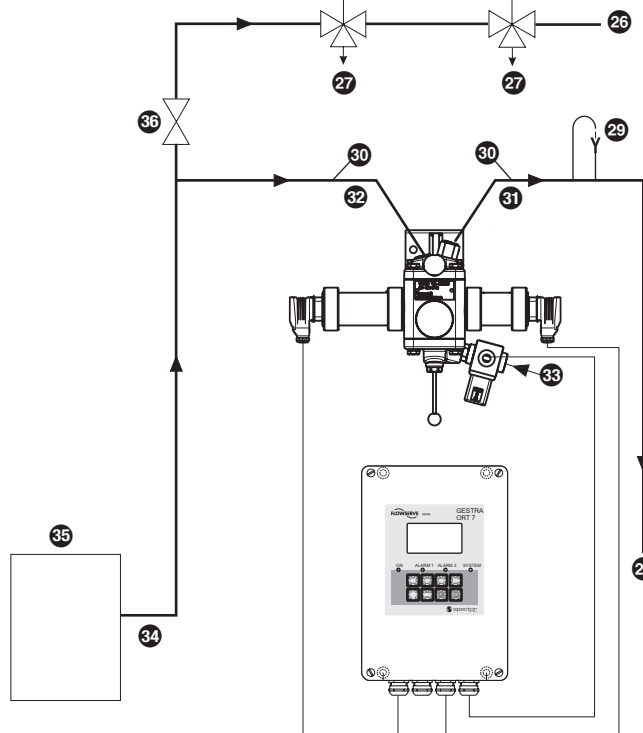

GESTRA AG

Münchener Straße 77, 28215 Bremen, Germany
Telefon +49 421 3503-0, Telefax +49 421 3503-393
E-mail info@de.gestra.com, Web www.gestra.de

