



GESTRA® Condensate Return Systems · Product Range Group C2

SDI
SDs

Condensate Recovery and Return Systems SDI / SDs

Application

The condensate from steam processors or flash vessels is collected in a condensate tank. From the tank the condensate is returned by a level-controlled pump - in most cases via a de-aerator. The pump pressure can be adjusted to the pump characteristic with the aid of the isolating valve (item 3.4) and the pressure gauge (item 3.5).

Capacity Range

The size of the tank depends on the amount of condensate formed. Our standard range comprises tanks for small capacities and tanks up to 14,200 litre for max. condensate flowrates of 60 m³/h (see table page 3). For larger capacities special designs are available.

Pressure/Temperature Rating

Max. service pressure	bar g	1.0	4.0
	psig	14.5	58.0
Max. temperature	°C	120	200

Max. condensate flowrate see table. Tanks for higher pressures, temperatures and flowrates on request.

Materials

SDI/SDs 1.0 (bar):
Steel - DIN reference St 37-2
(ASTM equivalent: A 283 Grade C)

SDI/SDs 4.0 (bar):
Steel - DIN reference H II
(ASTM equivalent: A 414 Grade C)

Supply

1. Tank without equipment
2. Tank with equipment, but supplied separately.
3. Tank with equipment assembled and interconnected, mounted on a base plate for connection to the pipe system and mains of the user (packaged unit).

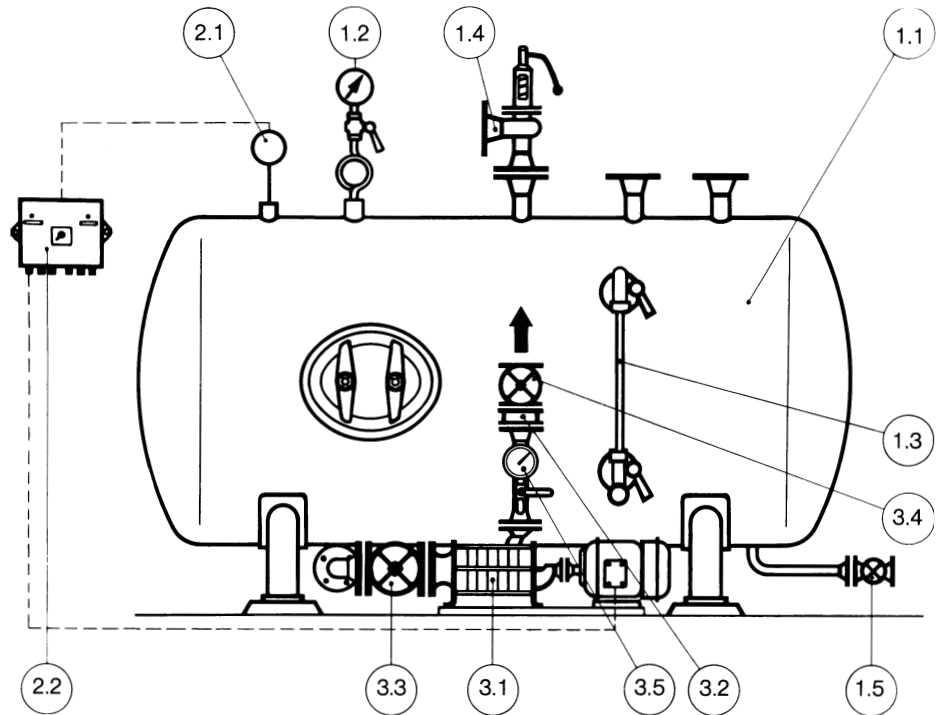

Equipment

- 1 Condensate tank equipped with**
 - 1.1 GESTRA condensate tank type SDI or SDs
 - 1.2 Pressure gauge, case diameter 100 mm, 1/2" BSP
 - 1.3 Water-level indicator
 - 1.4 Safety valve type GSV
 - 1.5 GESTRA drain valve type GAV 803
- 2 Level control equipment**
 - 2.1 GESTRA level control electrode type NRG or ER
 - 2.2 GESTRA pump control unit type SR
- 3 Pump unit**
 - 3.1 Condensate pump
 - 3.2 GESTRA Disco non-return valve type RK
 - 3.3 GESTRA isolating valve type GAV
 - 3.4 GESTRA isolating valve with regulating cone type GAV
 - 3.5 Pressure gauge for pump discharge line, case diameter 100 mm, 1/2" BSP

Design

Horizontal tanks type SDI or vertical tanks type SDs as illustrated, but from 10 m³ volume with oval support. Anti-rust painting on exposed external surface. On request, tanks from a diameter of 1000 mm can be supplied with the inside plastic-coated or completely of stainless steel.

For rectangular condensate tanks see data sheet SDR.

GESTRA condensate tank SDI

Horizontal design for max. condensate flowrates of 60 m³/h and a max. volume of 14.2 m³.

GESTRA condensate tank SDs

Vertical design for max. condensate flowrates of 16 m³/h and a max. volume of 3.8 m³.

Connections

- I Condensate inlet
- II Condensate outlet or condensate pump connection
- III Safety valve (does not apply to SDI and SDs 1.0 (bar) unless the tank is to be used in a closed system)
- IV Flash-steam outlet
- V Drain
- VI Measuring pot
- VII Water-level indicator
- VIII Pressure gauge
- IX Connection for electrode (applies only to SDI and SDs 1.0 (bar))
- X Submersible pump on request, at extra cost (only possible for SDI and SDs 1.0 (bar))
- XI Inspection or manhole (standard for tanks requiring TÜV inspection in Germany, otherwise on request, at extra cost)

GESTRA condensate tank SDI

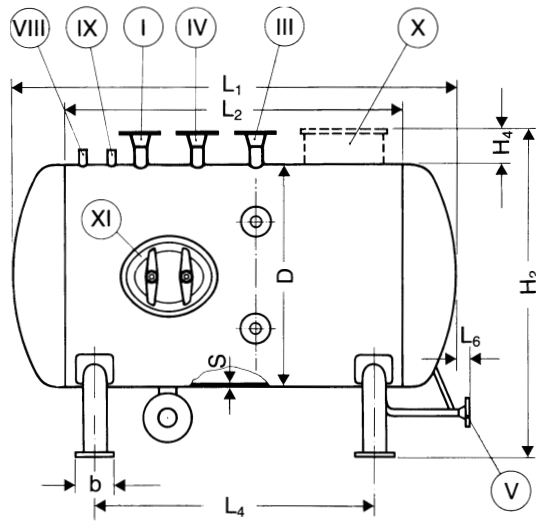

GESTRA condensate tank SDs

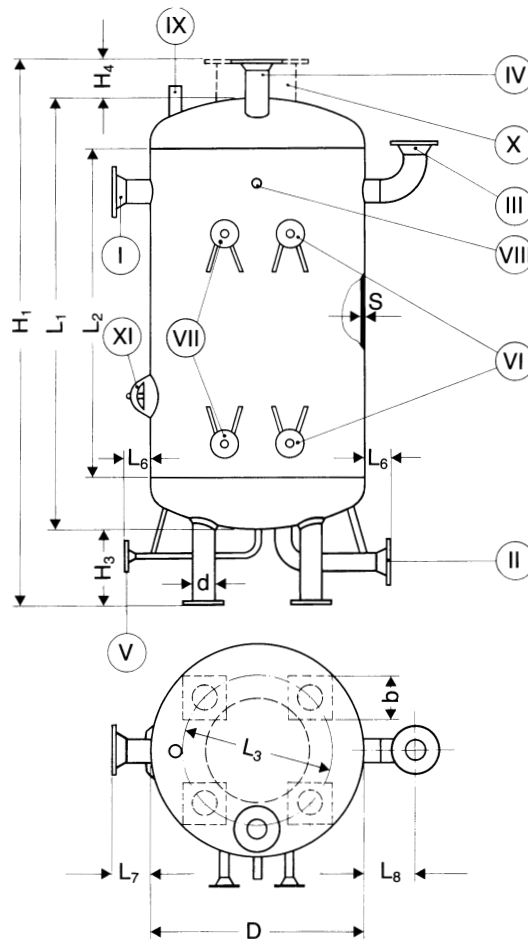

Dimensions and Weights

Tank size	1	2	3	4	5	6	7	8	9	10	11	12	13	14		
Max. condensate flowrate (m ³ /h)	1	2	4	6	9	12	16	20	25	30	35	43	50	60		
Volume (l)	250	390	850	1370	2100	2900	3800	4500	5900	6900	7900	10100	12700	14200		
Max. service bar pressure psi	1 14.5	1 14.5	1 14.5	1 14.5	1 14.5	1 14.5	1 14.5	1 14.5	1 14.5	1 14.5	1 14.5	1 14.5	1 14.5	1 14.5		
Dimensions (mm)	D	600	600	800	1000	1200	1400	1400	1400	1600	1600	1600	1800	2000	2000	Larger tanks on request
	s	5	5	5	5	5	5	5	5	5	5	5	5 (6) ⁴⁾	5 (6) ⁴⁾	5 (6) ⁴⁾	
	b	120	120	140	160	160	180	180	180	200	200	200	220 ¹⁾	220 ¹⁾	220 ¹⁾	
	d	60.3	60.3	88.9	114.3	114.3	139.7	139.7	139.7	168.3	168.3	168.3	-	-	-	
	L ₁	1000	1500	1894	1970	2050	2124	2628	3128	3214	3714	4214	4294	4374	4872	
	L ₂	700	1200	1500	1500	1500	1500	2000	2500	2500	3000	3500	3500	3500	4000	
	L ₃	480	480	640	800	960	1120	1120	-	-	-	-	-	-	-	
	L ₄	540	1000	1130	1130	1130	1140	1600	2000	2000	2200	2700	2700	2700	3200	
	L ₅	360	360	480	600	720	840	840	840	960	960	960	1560 ²⁾	1740 ²⁾	1740 ²⁾	
	L ₆	100	100	100	100	100	120	120	120	120	120	120	150	150	150	
	L ₇	150	150	150	150	150	150	150	-	-	-	-	-	-	-	
	L ₈	140	150	160	165	180	190	190	-	-	-	-	-	-	-	
	H ₁	1400	1900	2344	2420	2500	2674	3178	-	-	-	-	-	-	-	
	H ₂	1000	1000	1250	1450	1650	1950	1950	1950	2150	2150	2150	2450	2750	2750	
	H ₃	250	250	300	300	300	400	400	400	400	400	400	500	600	600	
	H ₄	150	150	150	150	150	150	150	150	150	150	150	150	150	150	
Connections (DN in mm)	I	32	32	50	50	65	80	100	100	125	125	150	150	150	200	
	II	in acc. with pump connection														
	III	25	32	40	50	80	100	100	125	125	125	150	150	150	200	
	IV	50	65	65	80	100	125	125	150	150	150	200	200	200	250	
	V	25	25	32	32	32	32	32	32	40	40	40	40	40	40	
	VI	20	20	20	20	20	20	20	20	20	20	20	20	20	20	
	VII	20	20	20	20	20	20	20	20	20	20	20	20	20	20	
	VIII	1/2" BSP	1/2" BSP	1/2" BSP	1/2" BSP	1/2" BSP	1/2" BSP	1/2" BSP	1/2" BSP	1/2" BSP	1/2" BSP	1/2" BSP	1/2" BSP	1/2" BSP	1/2" BSP	
	IX	1" BSP	1" BSP	1" BSP	1" BSP	1" BSP	1" BSP	1" BSP	1" BSP	1" BSP	1" BSP	1" BSP	1" BSP	1" BSP	1" BSP	
	X	in acc. with pump connection														
XI ³⁾ (a × b)	100 × 150	100 × 150	2 × 100 × 150	2 × 100 × 150	320 × 420	320 × 420	320 × 420	320 × 420	320 × 420	320 × 420	320 × 420	320 × 420	320 × 420	320 × 420	320 × 420	
Weight	(N)	1030	1073	2453	3335	4120	5396	6278	7161	9123	10202	11282	17266	19620	22073	
	(kg)	105	140	250	340	420	550	640	730	930	1040	1150	1760	2000	2250	

Remarks: ¹⁾ Support length
²⁾ Support width

³⁾ For tanks with plastic-coated inside DN 500 mm, PN 6 only
⁴⁾ For SDI/SDs 4.0 (bar) only

Condensate Recovery and Return Systems SDI / SDs

Condensate Recovery and Return Systems

consisting of

- Item 1 Condensate tank type SDI or SDs
- 2 Pressure gauge
- 3 Water-level indicator with cock
- 4 Isolating valve type GAV
- 5 Full-lift spring-loaded safety valve type GSV
- 6 Steam trap type MK
- 7 Disco non-return valve type RK
- 8 Float trap type UNA
- 9 Level electrode type NRG or ER
- 10 Measuring pot
- 11 Isolating valve type GAV
- 12 Pump control unit type SR
- 13 Condensate pump
- 14 Disco non-return valve type RK
- 15 Isolating valve type GAV
- 16 Isolating valve type GAV
- 17 Pressure gauge, 1/2" BSP

Short Description

GESTRA condensate recovery and return system consisting of condensate tank with standard equipment, condensate pump(s) with pump equipment and control. Protection against pump running dry and pump change-over as a function of time, on request.

Open system

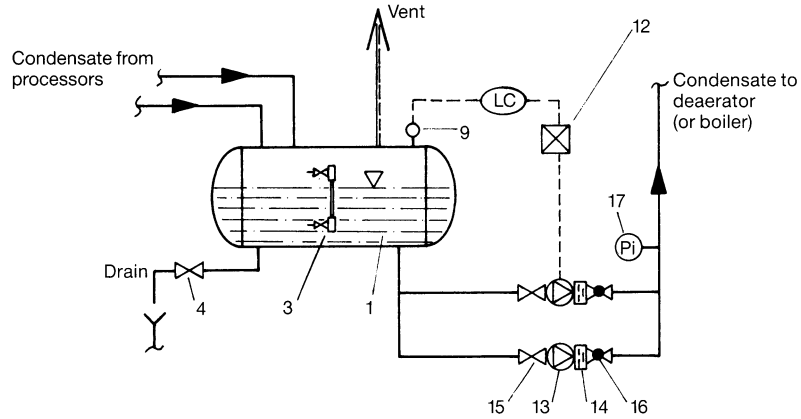

Closed system

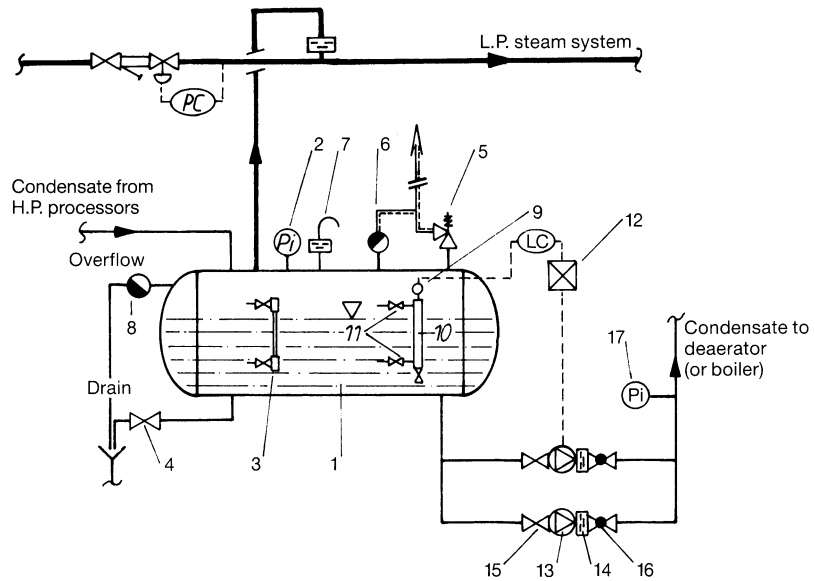

When ordering please state

Service pressure and temperature of steam processors
 Type of steam processor, quantity of condensate formed.
 Back pressure to be expected in pump discharge line.
 Mains voltage.

All inspection requirements have to be stated with the order. After supply of the equipment certification cannot be established. For tests and inspection charges please consult us.

Supply in accordance with our general terms of business.

Technical modifications reserved.



GESTRA AG

P. O. Box 10 54 60, D-28054 Bremen
 Münchener Str. 77, D-28215 Bremen

Telephone +49 (0) 421 35 03-0, Fax +49 (0) 421 35 03-393
 E-Mail gestra.ag@flowserve.com, Internet www.gestra.de



Flow Control Division