

Steam trap

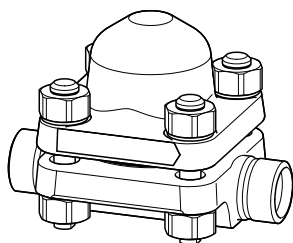

BK 37

BK 28

BK 29

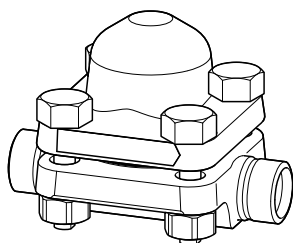

BK 37 ASME

BK 28 ASME

BK 29 ASME

Contents

Preface	3
Availability.....	3
Text layout	3
Safety	3
Usage for the intended purpose.....	3
Basic safety notes	4
Qualification of personnel.....	4
Protective gear	5
Typographic features of warning notes.....	5
Typographic features of information on environmental & property damage	5
Description	5
Scope of supply and equipment specification	5
Purpose and function.....	8
Storing and transporting the equipment	8
Storing the equipment	8
Transporting the equipment	9
Mounting and connecting the equipment	9
Preparing installation	9
Connecting the equipment	10
Operation	11
Activities during operation	11
After operation	11
Removing external dirt deposits	11
Maintaining the equipment.....	11
Servicing the equipment and installing spare parts	14
Troubleshooting	15
Putting the equipment out of operation	17
Removing harmful substances.....	17
Removing the equipment	18
Re-using equipment after storage.....	18
Disposing of the equipment.....	19
Technical data	20
Dimensions and weights	20
Pressure & temperature ratings.....	24
Manufacturer's Declaration	27

Preface

This installation & operating manual will help you use the following types of equipment safely and efficiently for their intended purpose.

- ▶ BK 37, PN 63
- ▶ BK 37 ASME, CL 400
- ▶ BK 28, PN 100
- ▶ BK 28 ASME, CL 600
- ▶ BK 29, PN 160
- ▶ BK 29 ASME, CL 900

These steam traps will be called equipment in this document.

This installation & operating manual is intended for anyone commissioning, using, operating, servicing, cleaning or disposing of this equipment and, in particular, for professional after-sales service technicians, qualified personnel and authorised and trained staff.

All of these persons must read and understand the content of this installation & operating manual.

Following the instructions given in this installation & operating manual helps avoiding danger and increases the reliability and service life of the equipment. Please note that in addition to the instructions given in this installation & operating manual you must also observe all locally applicable rules and regulations concerning the prevention of accidents as well as approved safety guidelines for good professional practice.

Availability

Keep this installation & operating manual together with the plant documentation for future reference. Make sure that this installation & operating manual is available to the operator.

The installation & operating manual is part of the equipment. Please hand over this installation & operating manual when selling the equipment or passing it on.

Text layout

Certain text elements of this installation & operating manual feature a specific typographic design. You can easily distinguish the following text elements:

Standard text

Cross-reference

- ▶ Listing
 - ▶ Sub-items in listings
- Steps for action.



Here you will find additional useful information and tips serving to assist you in using the equipment to its fullest potential.

Safety

Usage for the intended purpose

The following thermostatic/thermodynamic steam traps are installed in steam lines:

- ▶ BK 37, PN 63
- ▶ BK 37 ASME, CL 400
- ▶ BK 28, PN 100
- ▶ BK 28 ASME, CL 600
- ▶ BK 29, PN 160
- ▶ BK 29 ASME, CL 900

This equipment is designed for discharging condensed water or air-venting pipes.

The equipment must only be used within the allowable pressure and temperature limits and only if the chemical and corrosive influences on the equipment are taken into account.

Correct use includes compliance with the instructions given in this installation & operating manual, in particular obedience to all safety instructions.

Any other use of the equipment is considered to be improper.

Note that the equipment is also used incorrectly if the materials of the equipment are not suitable for the fluid.

Basic safety notes

Risk of severe injuries

- ▶ The equipment is under pressure during operation and may be hot. Before carrying out any work on the equipment make sure that the following requirements are met:
 - ▶ The pipes must be depressurized (0 bar).
 - ▶ The fluid must be completely removed from the pipes and the equipment.
 - ▶ During work on the equipment the installation must be switched off and protected against unauthorised or unintended activation.
 - ▶ The pipes and the equipment must have cooled down to room temperature (approx. 20 °C).
- ▶ If the equipment is used in contaminated areas there is a risk of severe injuries or death caused by harmful substances in or on the equipment. Before working on the equipment make sure that it is completely decontaminated. Always wear the protective clothing prescribed for contaminated areas when working on the equipment.
- ▶ The equipment must only be used with fluids that do not attack the material and the gaskets and sealings of the equipment. Otherwise leaks may occur and hot or toxic fluid could escape.
- ▶ The equipment and its component parts must only be mounted or removed by qualified personnel. A qualified person must be acquainted with and experienced in the following:
 - ▶ Making pipe connections.
 - ▶ Selecting suitable lifting gear and understanding the rules for its safe use.
 - ▶ Working with dangerous (contaminated, hot or pressurized) fluids.

Risk of minor injuries

- ▶ Sharp edges on internals present the danger of cuts to hands. Always wear industrial gloves when servicing the equipment.
- ▶ If the support of the equipment during installation is insufficient the equipment might fall down, thereby causing bruises or injuries. Make sure the equipment is safely held in place during installation and cannot fall down. Wear protective safety footwear.

Risk of property damage or malfunctions

- ▶ Malfunctions will occur if the equipment is installed in a wrong position or with the flow arrow pointing in the opposite direction of the fluid flow. This may result in damage to the equipment or the installation. Make sure that the flow arrow on the equipment body matches the indicated direction of the fluid flow in the pipe.
- ▶ If the material is unsuitable for the fluid, increased wear may occur and fluid may escape. Make sure that the material is suitable for the fluid used in your installation.

Qualification of personnel

A qualified person must be acquainted with and experienced in the following:

- ▶ the pertinent on-site rules and regulations for preventing fire and explosions as well as industrial safety regulations
- ▶ working on pressure equipment
- ▶ making pipe connections
- ▶ working with dangerous (hot or pressurized) fluids
- ▶ lifting and transporting loads
- ▶ observing all notes and instructions in this installation & operating manual and the applicable documents

Protective gear

The required protective gear depends on the types of fluid used and the regulations on site. For more information on suitable protective clothing and safety gear refer to the safety data sheet of the fluid in question.

Protective gear comprises the following items:

- ▶ Safety helmet to EN 397
- ▶ Safety footwear to EN ISO 20345
- ▶ Protective leather gloves to EN 388

Wear some form of ear protection to EN 352 when standing close to the equipment (1 m or less) during operation.

Typographic features of warning notes



DANGER

Notes with the heading DANGER warn against imminent dangerous situations that can lead to death or serious injuries.



WARNING

Notes with the heading WARNING warn against possibly dangerous situations that could lead to death or serious injuries.



CAUTION

Notes with the heading CAUTION warn against dangerous situations that could lead to minor or moderate injuries.

Typographic features of information on environmental & property damage

Attention!

This note warns against situations that may lead to environmental and/or property damage.

Description

Scope of supply and equipment specification

Scope of supply

Our equipment is delivered packed and ready for assembly.

Equipment specification

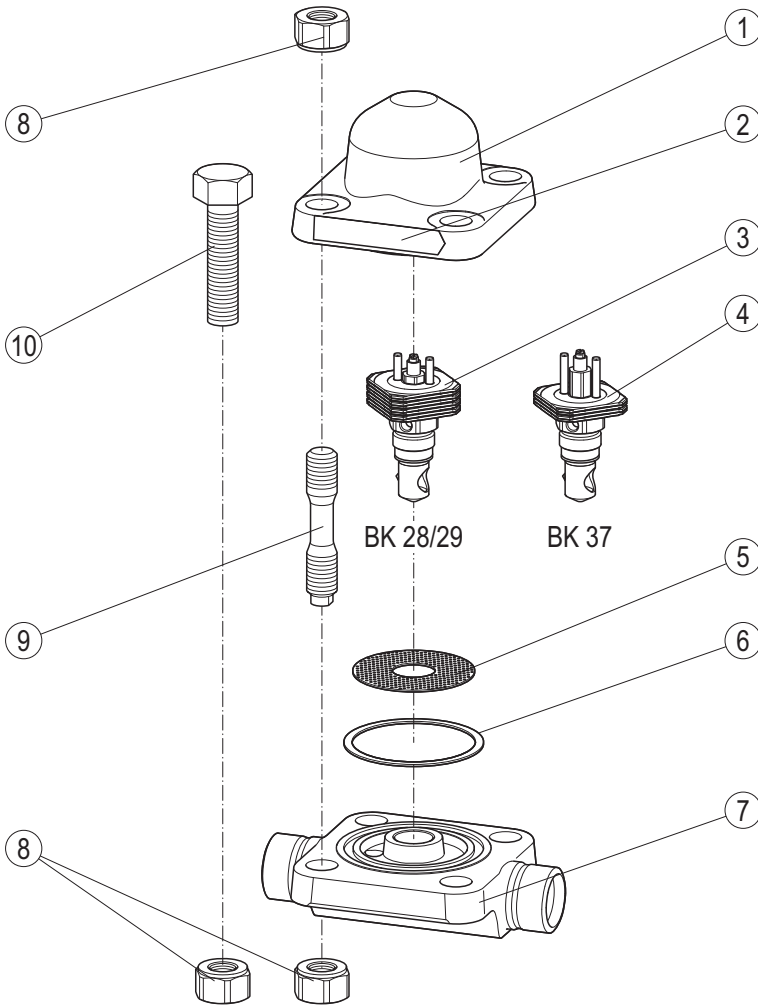

No.	Designation
1	Cover
2	Name plate
3	Thermovolt regulator BK 28/BK 29
4	Thermovolt regulator BK 37
5	Strainer

No.	Designation
6	Gasket
7	Body
8	Nuts
9	Stud bolts (only EN equipment)
10	Hexagon-head bolts (only ASME equipment)

Optional extras

The following add-on equipment is available:

- ▶ Ultrasonic test device VAPOPHONE®
- ▶ Continuous condensate monitoring equipment

End connections

The equipment is available with the following end connections:

- ▶ Flanges
- ▶ Butt-weld ends
- ▶ Socket-weld ends
- ▶ Screwed sockets

Name plate

The following items are indicated on the name plate:

- ▶ Manufacturer
- ▶ Type designation
- ▶ Nominal size
- ▶ Pressure rating
- ▶ Design temperature
- ▶ Design pressure
- ▶ Max. admissible differential pressure
- ▶ Direction of flow

The following items are indicated on the equipment body:

- ▶ Material
- ▶ Identification marking of material testing
- ▶ Batch code
- ▶ Direction of flow
- ▶ Manufacturing date (quarter/year)



Equipment with flanged ends has the manufacturing date indicated on the flange.

The following items are indicated on the end connections:

- ▶ Flange size
- ▶ Flange face type (RJ number)
- ▶ Thread type

PED (Pressure Equipment Directive)

The equipment fulfills the requirements of the Pressure Equipment Directive PED 97/23/EC and can be used for the following fluids:

- ▶ Fluids of group 2

The equipment is excluded from the scope of the PED according to section 3.3 and must not bear a CE marking.

ATEX

The equipment does not have its own potential source of ignition and is therefore not subject to the ATEX Directive 94/9/EC.

The equipment is not Ex marked.

- Please observe the following notes if the equipment is to be used in explosion-risk areas:
 - ▶ The equipment can be used in zones (surrounding atmosphere acc. to Directive 1999/92/EC) 0, 1, 2, 20, 21 and 22 (ATEX Directive 94/9/EC).
 - ▶ Make sure that the operating fluid does not generate a surface temperature that exceeds the limit specified for the place of installation.
 - ▶ If the equipment is electrically insulated when installed between pipe flanges appropriate measures must be taken to discharge any static electricity.

Purpose and function

Purpose

The equipment is designed for discharging condensed steam or air-venting pipelines.

The equipment features integral non-return valve action.

Function of the Thermovit controller

The equipment is fitted with a Thermovit regulator that regulates the flow of the fluid. The Thermovit regulator is screwed into the body.

The Thermovit regulator consists of a stack of several bimetallic plates. As the fluid temperature rises the plates deflect, thereby moving the stage nozzle. The orifice is being closed.

When the installation is cold the Thermovit regulator is open.

In the event of backflow, the pressure of the fluid forces the nozzle stem into the nozzle support. As a result the orifice is being closed.

Storing and transporting the equipment

Attention!

Equipment can be damaged if stored or transported improperly.

- Close all openings with the sealing plugs or covers supplied with the equipment or use similar sealing covers.
- Protect the equipment against moisture and corrosive atmospheres.
- Please contact the manufacturer if the specified transport and/or storage requirements cannot be met.

Storing the equipment

- Please observe the following items when storing the equipment:
 - Do not store the equipment for more than 12 months.
 - Use the supplied sealing plugs or other suitable seal caps in order to seal off all openings of the equipment.
 - Protect the sealing surfaces and contact areas against mechanical damage.
 - Protect the equipment and all components against hard shocks and impacts.
 - Store the equipment only in closed rooms that meet the following environmental conditions:
 - Air humidity below 50 %, not condensing
 - Indoor air: clean, salt-free and non-corrosive
 - Temperature 5–40 °C.
- Make sure that all these requirements are always met when storing the equipment.
- Please contact the manufacturer if you cannot comply with the recommended storage conditions.

Transporting the equipment

- Meet the requirements for storage also when transporting the equipment.
- Prior to transport seal off connections with sealing plugs.



If you do not have the sealing plugs supplied with the equipment use appropriate seal caps to seal off the connections.

- For short distances (only a few metres) you can transport the equipment unpacked.
- When transporting the equipment over larger distances use the original packaging.
- If you do not have the original packaging use a box that protects the equipment adequately against corrosion and physical damage.



For a short period of time the equipment may be transported even if the temperature is below 0 °C, provided that the equipment is completely empty and dry.

Mounting and connecting the equipment

Preparing installation

- Take the equipment out of the transport packaging.
- Check the equipment for transport damage.
- Contact the manufacturer if you detect any kind of shipping damage.

When supplied by the factory, the connections may be sealed off with sealing plugs.

- Remove sealing plugs before mounting the equipment.
- Keep the sealing plugs and the packing for further use.



DANGER

Personnel working on pipes are exposed to safety risks and may suffer severe injuries, poisoning or even loss of life.

- Make sure that no hot or hazardous fluid is in the equipment or the pipes.
- Make sure that the pipes upstream and downstream of the equipment are depressurised.
- Make sure that the installation is switched off and protected against unauthorised or unintended activation.
- Make sure that the equipment and the pipes have cooled down to room temperatures.
- Wear protective clothing that is suitable for the fluid and, if necessary, wear protective gear.

For more information on suitable protective clothing and safety gear refer to the safety data sheet of the fluid in question.

- Drain pipes until they are empty.
- Switch the installation off and protect it against unauthorised or unintended re-activation.

Connecting the equipment



DANGER

Incorrectly connected equipment can cause fatal accidents or severe injuries.

- Make sure that only qualified skilled personnel connect the equipment to pipes.
 - Make sure that the flow arrow on the equipment body matches the direction of flow in the pipe.
-

Specialist personnel must be highly qualified and fully experienced in making pipe connections for the respective type of end connection.

Attention!

Equipment will be damaged if the end connections are undersized.

- Make sure that the connections are strong and rigid enough to support the weight of the equipment and to withstand the forces that occur during operation.
-

To allow easy access for routine servicing and exchanging components observe the indicated withdrawal distances and allow for clearances to adjacent installation parts.

For more information see chapter "*Dimensions and weights*" on page 20.

- Make sure that the pipe system of the plant is clean.

The equipment can be installed in any position.

If the equipment is installed in a horizontal line the cover should be on top.

- Make sure that the equipment is free from foreign matter.
- Mount the equipment in the desired installation position.

- Make sure that the equipment is safely mounted and that all connections are made correctly.
-

Attention!

Malfunctions may occur if the equipment or condensate line is insulated.

- Make sure that the heat generated by the equipment or the condensate line is dissipated.
-

Operation

Activities during operation

You can check the equipment for correct operation using the GESTRA ultrasonic measuring unit VAPOPHONE®.

- For more details refer to the installation & operating manual of the ultrasonic measuring unit.

Continuous steam trap monitoring is recommended for critical applications.

- For more details refer to the installation & operating manual of the continuous steam trap monitoring unit.

After operation



DANGER

If the equipment is used in contaminated areas there is a risk of severe injuries or death caused by harmful substances in or on the equipment.

- Only qualified personnel are allowed to perform work on contaminated equipment.
- Always wear the protective clothing prescribed for contaminated areas when working on the equipment.
- Make sure that the equipment is completely decontaminated before carrying out any service work.
- Follow the pertinent instructions for handling the hazardous substances in question.

Attention!

Frost damage may occur when the installation is shut down.

- Drain the equipment if ambient temperatures below 0 °C (frost) are to be expected.

Removing external dirt deposits

- To remove dirt deposits rinse the equipment with fresh water and wipe it with a clean, lint-free cloth.
- To remove any persistent residues use a cleaning agent that is suitable for the material and carefully wipe the equipment with a clean, lint-free cloth.

Maintaining the equipment

To disassemble the equipment use the following tools:

- ◆ Combination spanner A. F. 24, DIN 3113, form B
- ◆ Torque spanner (US: torque wrench) 20–100 Nm, ISO 6789

Before assembling the equipment apply heat resistant lubricant to seating surfaces and threads. A suitable lubricant is, for example, OKS 217.



Malfunctions may occur if the equipment is used with different types of condensate: The following condensates in particular cause problems:

- very oily condensates
- condensates that resinify or become gummy
- condensates that recrystallize
- condensates that contain solid matter.

In these cases check the equipment at regular intervals for contamination and, if necessary, remove dirt deposits.

To reduce contamination we recommend installing a sedimentation vessel or a dirt pocket arrangement upstream of the equipment.

Normally you do not have to clean the internal parts of the equipment.

To clean the equipment completely take off the cover and remove the Thermovit regulator.

Removing Thermovit regulator

To clean the Thermovit regulator and, if necessary, replace it with a new one proceed as follows:



The cover and body of the BK 37, BK 28 and BK 29 are attached to each other by means of stud bolts (9).

The cover and body of the BK 37 ASME, BK 28 ASME and BK 29 ASME are attached to each other by means of hexagon-head bolts.

The procedure to detach the cover is the same for all types of equipment.

The following section and drawing refer to equipment with stud bolts.

- Loosen the nuts (8) on the stud bolts.
- Remove the stud bolts (9).
- Lift the cover (1) off the body (7).
- Remove the gasket (6).
- Use an open-end spanner (US: wrench) to unscrew the Thermovit regulator (3) from the body.

- Remove the strainer (5).



The following drawing shows EN equipment. Instead of stud bolts (9) with two nuts (8) per bolt ASME equipment has hexagon-head bolts with one nut per bolt.

- Proceed with ASME equipment in the same way as with EN equipment.

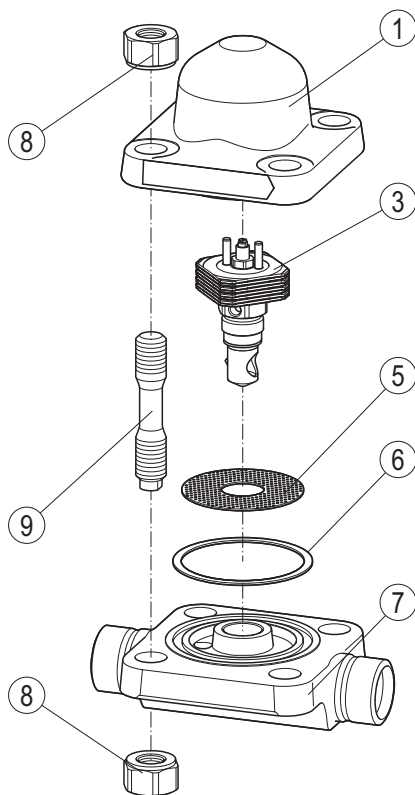

Cleaning Thermovit regulator

- Clean the Thermovit regulator with fresh water and a clean lint-free cloth.
- Clean gasket seating surfaces.

Checking the component parts for damage

- Check the removed parts for visible signs of wear or damage.
- Discard and replace any damaged part.

Removing and cleaning the strainer

To replace the strainer proceed as follows:

- Remove the Thermovit regulator as described in section "*Removing Thermovit regulator*" from page 12 onwards.
- Take out the strainer.
- Clean the gasket and the strainer with fresh water and a clean lint-free cloth.
- Clean gasket seating surfaces.

Mounting the strainer

- Apply heat-resistant lubricant to the threads.
- If the gasket is damaged replace it with a new one.
- Put the strainer and the gasket into the body.
- Screw the Thermovit regulator with a torque of 100 Nm into the body.
- Put the cover onto the body.
- Use nuts and bolts to fix the cover to the body.

The torque required for tightening the nuts and bolts that fix the cover to the body depends on the equipment type.

- BK 37, BK 37 ASME, BK 28, BK 28 ASME: 60 Nm
 - BK 29, BK 29 ASME: 80 Nm
- Fasten all nuts with the specified tightening torque.

Installing Thermovit regulator

To fit the Thermovit regulator proceed as follows:

- Apply heat-resistant lubricant (OKS 217) to the following surfaces:
 - all threads
 - the seating surface of the cover
- If the gasket is damaged replace it with a new one.
- Put the strainer and the gasket into the body.
- Screw the Thermovit regulator with a torque of 100 Nm into the body.
- Put the cover onto the body.
- Use nuts and bolts to fix the cover to the body.

The torque required for tightening the nuts and bolts that fix the cover to the body depends on the equipment type.

- BK 37, BK 37 ASME, BK 28, BK 28 ASME: 60 Nm
 - BK 29, BK 29 ASME: 80 Nm
- Fasten all nuts with the specified tightening torque.

Servicing the equipment and installing spare parts

You may exchange the following component parts in case of wear or damage:

- ▶ Thermovit regulator
- ▶ Strainer
- ▶ Gasket

To disassemble the equipment use the following tools:

- ▶ Combination spanner A. F. 24, DIN 3113, form B
- ▶ Torque spanner (US: torque wrench) 20–100 Nm, ISO 6789

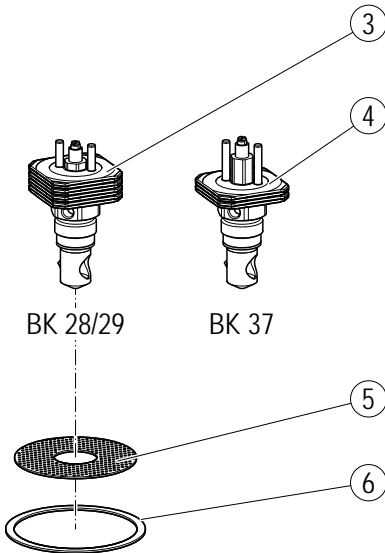

No.	Designation	Stock code #
3, 6	Spare parts kit for BK 28 and BK 28 ASME, cpl. with gasket	379825
	Spare parts kit for BK 29 and BK 29 ASME, cpl. with gasket	379826
4, 6	Spare parts kit for BK 37 and BK 37 ASME, cpl. with gasket	377722
5	Strainer	096701
6	Gasket for BK 28 and BK 28 ASME	086519
	Gasket for BK 37 and BK 37 ASME	
	Gasket for BK 29 and BK 29 ASME	372095

Exchanging Thermovit regulator

- Remove the Thermovit regulator as described in section "*Removing Thermovit regulator*" from page 12 onwards.
- Install the new Thermovit regulator as described in section "*Installing Thermovit regulator*" from page 13 onwards.

Replacing strainer

- Remove the strainer as described in section "*Removing and cleaning the strainer*" from page 13 onwards.
- Install a new strainer as described in section "*Mounting the strainer*" from page 13 onwards.

Troubleshooting

Problem	Cause	Remedy
The steam trap is cold or only hand-hot.	The shut-off valves for condensate inlet or outlet are closed.	Open the isolating valves.
	The condensate inlet or outlet is dirt clogged.	Clean the pipes. Clean the equipment.
The steam trap is blowing off live steam.	The Thermovit regulator is contaminated. There are dirt deposits in the equipment.	Clean the Thermovit regulator. Clean the strainer and the equipment. Replace the Thermovit regulator with a new one.
	The Thermovit regulator is worn down. The seat is leaking.	Replace the Thermovit regulator with a new one.
	The bypass is open.	Close the bypass.
Fluid escapes (equipment is leaking).	The end connections are not tight.	Seal off the end connections (e. g. flanged or screwed ends).
	A gasket on the body is defective.	Replace the gasket with a new one.
	The body has been damaged by corrosion or erosion.	Check the resistance of the material for the fluid used. Use a steam trap made from a material that is suitable for the fluid used.
	The equipment has been damaged by frost.	Replace the equipment with a new one. When shutting down the installation make sure that the condensate lines and the steam trap are completely drained.
	The equipment has been damaged by waterhammer.	Replace the equipment with a new one. Take appropriate measures to protect the equipment against waterhammer, e. g. by installing suitable non-return valves.

Problem	Cause	Remedy
<p>Insufficient condensate discharge.</p> <p>Insufficient thermal output of the user.</p>	The shut-off valves for condensate inlet or outlet are closed.	Open the isolating valves.
	The condensate inlet or outlet is dirt clogged.	Clean the pipes. Clean the equipment.
	Steam pressure and condensate flowrate fluctuate considerably. The pressure upstream of the steam trap is too low for the used trap type.	Use a different steam trap type. Contact the manufacturer to find out which trap type is the most suitable for your application.
	The steam trap is undersized.	Use a steam trap with a larger condensate discharge capacity.
	The differential pressure is too small.	Increase the steam pressure. Lower the pressure in the condensate line. Check the size of the condensate line. Install a steam trap with a larger condensate discharge capacity, a pump steam trap or a condensate return unit.
	The pressure upstream of the steam trap is too low. The pressure in the condensate line is too high.	Use a different steam trap type. Contact the manufacturer to find out which trap type is the most suitable for your application.
	The distance between the drain point and the steam trap is too small.	Install the steam trap approx. 1 - 2 m away from the drain point. Lay the condensate line with a gradient so that the condensate is free to fall towards the steam trap.
	The condensate line does not have a slight fall from the drain point towards the steam trap. The condensate is lifted upstream of the steam trap.	Lay the condensate line with a gradient so that the condensate is free to fall towards the steam trap. Change the orientation of the condensate line.
	The condensate temperature is higher than the service temperature of the steam trap. The Thermovit regulator does not open or only with a time delay.	If the steam trap or the condensate line is insulated remove the insulation. Use a different steam trap type. Contact the manufacturer to find out which trap type is the most suitable for your application.

Problem	Cause	Remedy
	Insufficient deaeration.	Provide additional deaeration. Use a different steam trap type. Contact the manufacturer to find out which trap type is the most suitable for your application.

- If faults occur that are not listed above or cannot be corrected, please contact our Technical Service or authorized agency in your country.

Putting the equipment out of operation

Removing harmful substances



DANGER

If the equipment is used in contaminated areas there is a risk of severe injuries or death caused by harmful substances in or on the equipment.

- Only qualified personnel are allowed to perform work on contaminated equipment.
- Always wear the protective clothing prescribed for contaminated areas when working on the equipment.
- Make sure that the equipment is completely decontaminated before carrying out any service work.
- Follow the pertinent instructions for handling the hazardous substances in question.

Qualified personnel must have extensive experience with and a working knowledge of:

- ▶ pertinent rules and regulations concerning handling hazardous substances
- ▶ special regulations for handling the hazardous substances encountered on site
- ▶ using the required personal protective equipment (PPE) and clothing

Attention!

Environmental damage may be caused by poisonous fluid residues.

- Before disposing of the equipment make sure that it is clean and free of fluid residues.
 - For the disposal of all materials observe the pertinent legal regulations concerning waste disposal.
-
- Remove all residues from the equipment.
 - For the disposal of all residues observe the pertinent legal regulations concerning waste disposal.

Removing the equipment



DANGER

Personnel working on pipes are exposed to safety risks and may suffer severe injuries, poisoning or even loss of life.

- Make sure that no hot or hazardous fluid is in the equipment or the pipes.
- Make sure that the pipes upstream and downstream of the equipment are depressurised.
- Make sure that the installation is switched off and protected against unauthorised or unintended activation.
- Make sure that the equipment and the pipes have cooled down to room temperatures.
- Wear protective clothing that is suitable for the fluid and, if necessary, wear protective gear.

For more information on suitable protective clothing and safety gear refer to the safety data sheet of the fluid in question.



CAUTION

Danger of bruising if the equipment falls down.

- When removing the equipment make sure the it is safely held in place and cannot fall down.

Suitable measures are for instance:

- Equipment that is not too heavy may be supported by a second person.
- For heavy equipment use suitable lifting equipment of sufficient strength.
- Detach the end connections of the equipment from the pipes.
- Put the equipment onto a suitable base.

- Store the equipment as described in section "Storing the equipment" from page 8 onwards.

Re-using equipment after storage

Observe the following instructions if you want to remove the equipment and use it again somewhere else:

- Make sure that the equipment is free of any fluid residues.
- Make sure that all connections are in good condition and leak-free.
- If necessary re-work welded connections in order to ensure that they are in good working condition.
- Use the equipment only for its intended purpose and the service conditions for which it was specified.

Disposing of the equipment

Attention!

Environmental damage may be caused by poisonous fluid residues.

- Before disposing of the equipment make sure that it is clean and free of fluid residues.
- For the disposal of all materials observe the pertinent legal regulations concerning waste disposal.

The equipment is made from the following materials:

Component	DIN / EN	ASME
Body and cover BK 37, BK 28	1.5415	A182F12
Body and cover BK 29	1.7335	
Bolts	1.7709	A193B7
Nuts	1.7709	A194Gr.4
Gasket	Graphite/CrNi	
Thermovit regulator	Stainless steel	
Nozzle stem and seat	Titan alloy	
Other internals	Stainless steel	

Technical data

Dimensions and weights

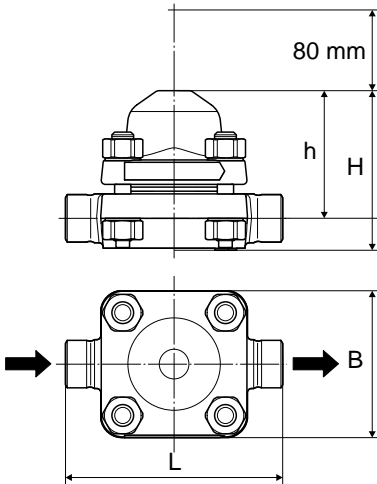

All types of equipment

	Dimensions	
	[mm]	[inch]
Height h	92	3.622
Overall height H	115	5.91
Width of cover B	110	4.33
Space required for servicing cover	80	3.15

Dimensions and weights BK 37

BK 37 with flanged ends

	EN 1092-1, PN 63			ASME B 16.5, Class 400/600		
Nominal size [mm]	15	20	25	15	20	25
Nominal size [inch]	½	¾	1	½	¾	1
Diameter of flange D [mm]	105	130	140	95	115	125
Length L [mm]	210	230	230	230	230	230
Weight [kg]	8	9	10	7	9	9

BK 37 with butt-weld ends

	EN 12627 Edge form to ISO 9692, code number 1.3			ASME B 16.25 ASME B 36.10		
Nominal size [mm]	15	20	25	15	20	25
Nominal size [inch]	½	¾	1	½	¾	1
for tube [mm]	21.3 × 2.0	26.9 × 2.6	33.7 × 2.6	21.3 × 3.73	26.7 × 3.91	33.4 × 3.38
Overall length L [mm]	160	160	160	160	160	160
Weight [kg]	5.0	5.0	5.0	5.1	5.1	5.1

BK 37 with socket-weld ends

	DIN EN 12760 Class 3000, ASME B16.11		
Nominal size [mm]	15	20	25
Nominal size [inch]	½	¾	1
Overall length L [mm]	160	160	160
Weight [kg]	5.1	5.1	5.1

Dimensions and weights BK 28

BK 28 with flanged ends

	EN 1092-1, PN 100			ASME B 16.5, Class 600		
Nominal size [mm]	15	20	25	15	20	25
Nominal size [inch]	½	¾	1	½	¾	1
Diameter of flange D [mm]	105	130	140	95	115	125
Overall length L [mm]	210	230	230	230	230	230
Weight [kg]	8	9	10	7	9	9

BK 28 with butt-weld ends

	EN 12627 Edge form to ISO 9692, code number 1.3			ASME B 16.25 ASME B 36.10		
Nominal size [mm]	15	20	25	15	20	25
Nominal size [inch]	½	¾	1	½	¾	1
for tube [mm]	21.3 × 2.0	26.9 × 2.6	33.7 × 2.6	21.3 × 3.73	26.7 × 3.91	33.4 × 3.38
Overall length L [mm]	160	160	160	160	160	160
Weight [kg]	5.0	5.0	5.0	5.1	5.1	5.1

BK 28 with socket-weld ends

	DIN EN 12760 Class 3000, ASME B16.11		
Nominal size [mm]	15	20	25
Nominal size [inch]	½	¾	1
Overall length L [mm]	160	160	160
Weight [kg]	5.1	5.1	5.1

Dimensions and weights BK 29

BK 29 with flanged ends

	EN 1092-1, PN 160			ASME B 16.5, Class 900/1500		
Nominal size [mm]	15	20	25	15	20	25
Nominal size [inch]	½	¾	1	½	¾	1
Diameter of flange D [mm]	105	–	140	120	130	150
Overall length L [mm]	210	–	230	230	230	254
Weight [kg]	8	–	10	10	11	14

BK 29 with butt-weld ends

	EN 12627 Edge form to ISO 9692, code number 1.3			ASME B 16.25 ASME B 36.10		
Nominal size [mm]	15	20	25	15	20	25
Nominal size [inch]	½	¾	1	½	¾	1
for tube [mm]	21.3 × 2.0	26.9 × 2.6	33.7 × 2.6	21.3 × 3.73	26.7 × 3.91	33.4 × 3.38
Overall length L [mm]	160	160	160	200	200	200
Weight [kg]	5.0	5.0	5.0	5.1	5.1	5.1

BK 29 with socket-weld ends

	DIN EN 12760			Class 6000, ASME B16.11		
Nominal size [mm]	15	20	25	15	20	25
Nominal size [inch]	½	¾	1	½	¾	1
Overall length L [mm]	160	160	160	200	200	200
Weight [kg]	5.1	5.1	5.1	5.1	5.1	5.1

Pressure & temperature ratings

Limiting conditions BK 37

End connection	Flanged PN 63, EN 1092-1 (2002)					
p (service pressure) [bar]	100.0	100.0	94.0	80.9	73.0	44.2
T (inlet temperature) [°C]	20	150	265	350	415	500
Differential pressure ΔPMX [bar]	45					

Based on EN 1092-1

End connection	Butt-weld ends to DIN EN 12627 Butt-weld ends to DIN EN 12760					
p (service pressure) [bar]	100.0	100.0	100	85.0	61.0	30.9
T (inlet temperature) [°C]	20	400	450	470	500	530
Differential pressure ΔPMX [bar]	45					

Calculated in accordance with DIN EN 12516-2

End connection	Flanges B16.5, CLASS 400/600 Butt-weld ends B16.25, Sched.80 Socket-weld ends B16.11, CLASS 3000					
p (service pressure) [bar]	103.4	100.9	85.7	73.3	67.7	42.8
T (inlet temperature) [°C]	20	100	300	400	450	500
Differential pressure ΔPMX [bar]	45					

Calculated in accordance with ASME B16.34

Limiting conditions BK 28

End connection	Flanged PN 100, EN 1092-1 (2002)					
p (service pressure) [bar]	100.0	100.0	94.0	80.9	73.0	44.2
T (inlet temperature) [°C]	20	150	265	350	415	500
Differential pressure ΔPMX [bar]	85					

Based on EN 1092-1

End connection	Butt-weld ends to DIN EN 12627 Butt-weld ends to DIN EN 12760					
p (service pressure) [bar]	100.0	100.0	100	85.0	61.0	30.9
T (inlet temperature) [°C]	20	400	450	470	500	530
Differential pressure ΔPMX [bar]	85					

Calculated in accordance with DIN EN 12516-2

End connection	Flanges B16.5, CLASS 600 Butt-weld ends B16.25, Sched.80 Socket-weld ends B16.11, CLASS 3000					
p (service pressure) [bar]	103.4	100.9	85.7	73.3	67.7	42.8
T (inlet temperature) [°C]	20	100	300	400	450	500
Differential pressure ΔPMX [bar]	85					

Calculated in accordance with ASME B16.34

Limiting conditions BK 29

End connection	Flanged PN 160, EN 1092-1 (2002)					
p (service pressure) [bar]	160.0	144.0	134.8	112.0	104.3	59.4
T (inlet temperature) [°C]	20	400	450	485	500	530
Differential pressure Δ PMX [bar]	110					

Based on EN 1092-1

End connection	Butt-weld ends to DIN EN 12627 Butt-weld ends to DIN EN 12760					
p (service pressure) [bar]	160.0	144.0	134.8	104.3	59.4	46.4
T (inlet temperature) [°C]	20	400	450	500	530	540
Differential pressure Δ PMX [bar]	110					

Calculated in accordance with DIN EN 12516-2

End connection	Flanges B16.5, CLASS 900/1500 Butt-weld ends B16.25, Sched.160 Socket-weld ends B16.11, CLASS 6000					
p (service pressure) [bar]	155.1	128.6	101.4	64.1	45.9	40.2
T (inlet temperature) [°C]	20	300	450	500	530	540
Differential pressure Δ PMX [bar]	110					

Calculated in accordance with ASME B16.34

Manufacturer's Declaration

For more information on the Conformity Assessment according to European rules refer to our Declaration of Conformity or our Declaration by Manufacturer.

To download the current Declaration of Conformity or Declaration by Manufacturer go to www.gestra.en/documents or contact:

Manufacturer GESTRA AG
P. O. Box 10 54 60, D-28054
Bremen

Telephone +49 (0) 421 35 03 0
Fax +49 (0) 421 35 03 393
E mail gestra.ag@flowserve.com
Internet www.gestra.com

This declaration is no longer valid if modifications are made to the equipment without consultation with us.



GESTRA

Agencies all over the world: www.gestra.de

Great Britain

Flowserve GB Limited

Abex Road
Newbury, Berkshire RG14 5EY
Tel. 0044 16 35 / 46 99 90
Fax 0044 16 35 / 3 60 34
E-Mail gestraukinfo@flowserve.com
Web www.flowserve.com

South Africa

Flowserve SA (Pty) Ltd.

Unit No. 1
Director Road
Spartan Extension 2
Kempton Park 1613
P.O.Box 9279
Edenglen 1613
Tel. 0027 11 / 9 23 73 00
Fax 0027 11 / 9 74 64 20
E-Mail tvniekerk@flowserve.com
Web www.flowserve.com

Singapore

Flowserve Pte. Ltd.

12 Tuas Avenue 20
Singapore 638824
Tel. 0065 / 68 79 89 00
Fax 0065 / 68 62 49 40
E-Mail rgoh@flowserve.com

USA

Flowserve GESTRA U.S.

2341 Ampere Drive
Louisville, KY 40299
Tel. 001 502 / 267 - 2205
001 502 / 267 - 2206
Fax 001 502 / 266 - 5397
E-Mail fcd-gestra-usa@flowserve.com
Web www.flowserve.com

GESTRA AG

P. O. Box 10 54 60, D-28054 Bremen
Münchener Str. 77, D-28215 Bremen
Telephone 0049 (0) 421 / 35 03 - 0
Fax 0049 (0) 421 / 35 03 - 393
E mail gestra.ag@flowserve.com
Internet www.gestra.de

