

GESTRA Steam Drier/Steam Purifier Type TD

Task

Liquids, entrained water droplets and impurities are separated from the flow of steam with little loss of pressure by a cyclone separator by a process of mechanical separation.

Purpose

Steam driers/steam purifiers separate water, suspended liquids and dirt from the steam phase. The equipment ensures a trouble-free work process and a long service life for heat exchangers and steam consumers.

Method of operation

Separation is achieved by exploiting centrifugal forces several times over, with the aid of a fixed two-start helix welded securely to the jacket of the equipment.

Larger dirt particles collect in the sump situated centrally below the drier, which is sealed by a stop valve and must be opened to remove impurities when a certain amount is present.

Liquid that forms and any impurities it may contain (small dirt particles) are removed via the ball-float steam trap connected to the condensate drain.

Function

The steam drier and purifier performs both of these functions simultaneously or individually and ensures highly effective separation, it is maintenance-free and has minimal space requirements.

The humid, impure steam flows through the fixed helix in a downward spiral, and when it is above the sump cover plate the flow is reversed 180 degrees. The resulting centrifugal forces as well as impact and swirling effects separate heavier particles such as liquid, suspended moisture, dirt, scale, etc. from steam, which is the lighter medium, and conveys them to the collecting chamber. The abrupt reversal of the flow of steam from one side of the helix to the other prevents the unwanted re-entrainment of the particles after separation.

The equipment can achieve up to 98-99% dryness.

Design

No moving parts are installed. The sole operating component is the guide helix – a fixed two-start helix that is welded to the jacket. One start of the helix is connected to the inlet connection, the second to the outlet connection.

The steam drier/purifier is made of an all welded construction. Horizontal connections are possible, as are special designs with pipe bend for a vertical inlet/horizontal outlet and vice versa; a direct vertical inlet is also possible.

The size of the helix must be adapted for each particular application.

Sump cover plate. Drain connection.

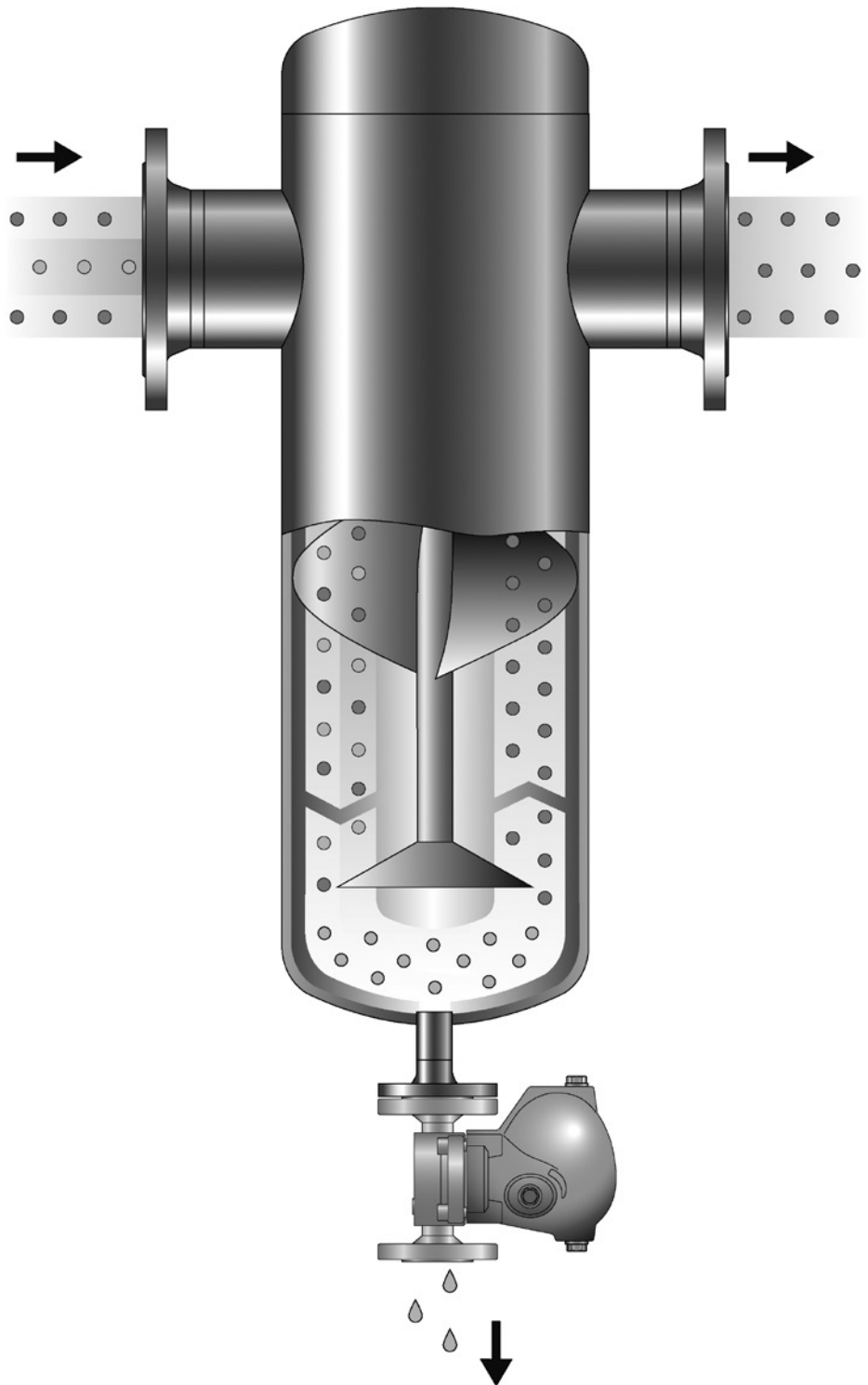

Application examples

- Downstream from steam boilers and high-speed steam generating units
- Between the boiler and the superheater
- In steam pipes upstream from the main manifold
- In district heating pipes and wet steam pipes
- Upstream from turbines, engines and steam-operated tools
- For direct exposure to steam
- For steam humidifiers in air conditioning systems.

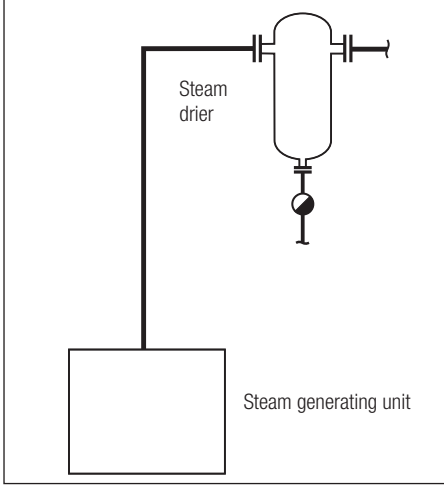

Steam drier downstream from a steam generating unit

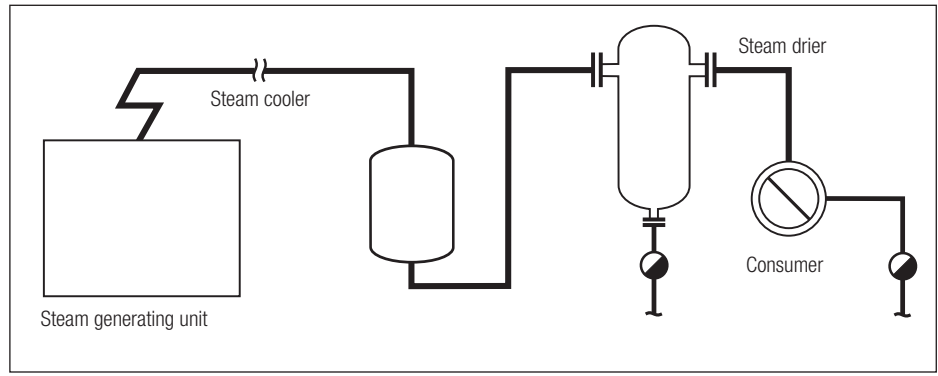

Steam drier upstream from a heat exchanger

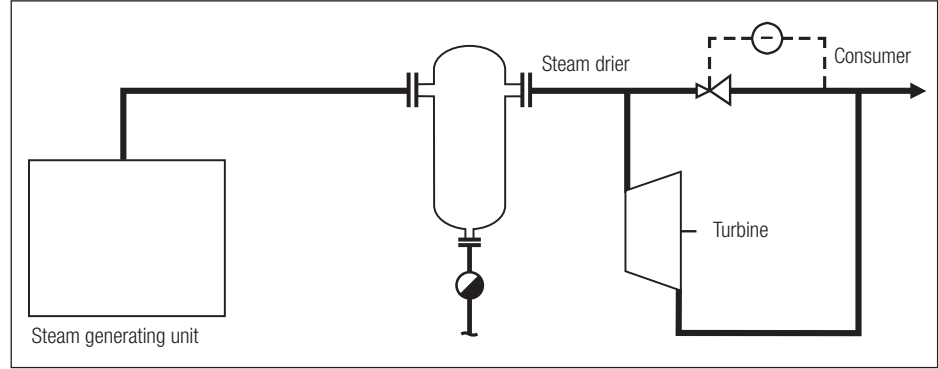

Steam drier upstream from a turbine

Equipment selection

Equipment is selected based on the operating data, i.e. the steam mass flowrate and the steam pressure.

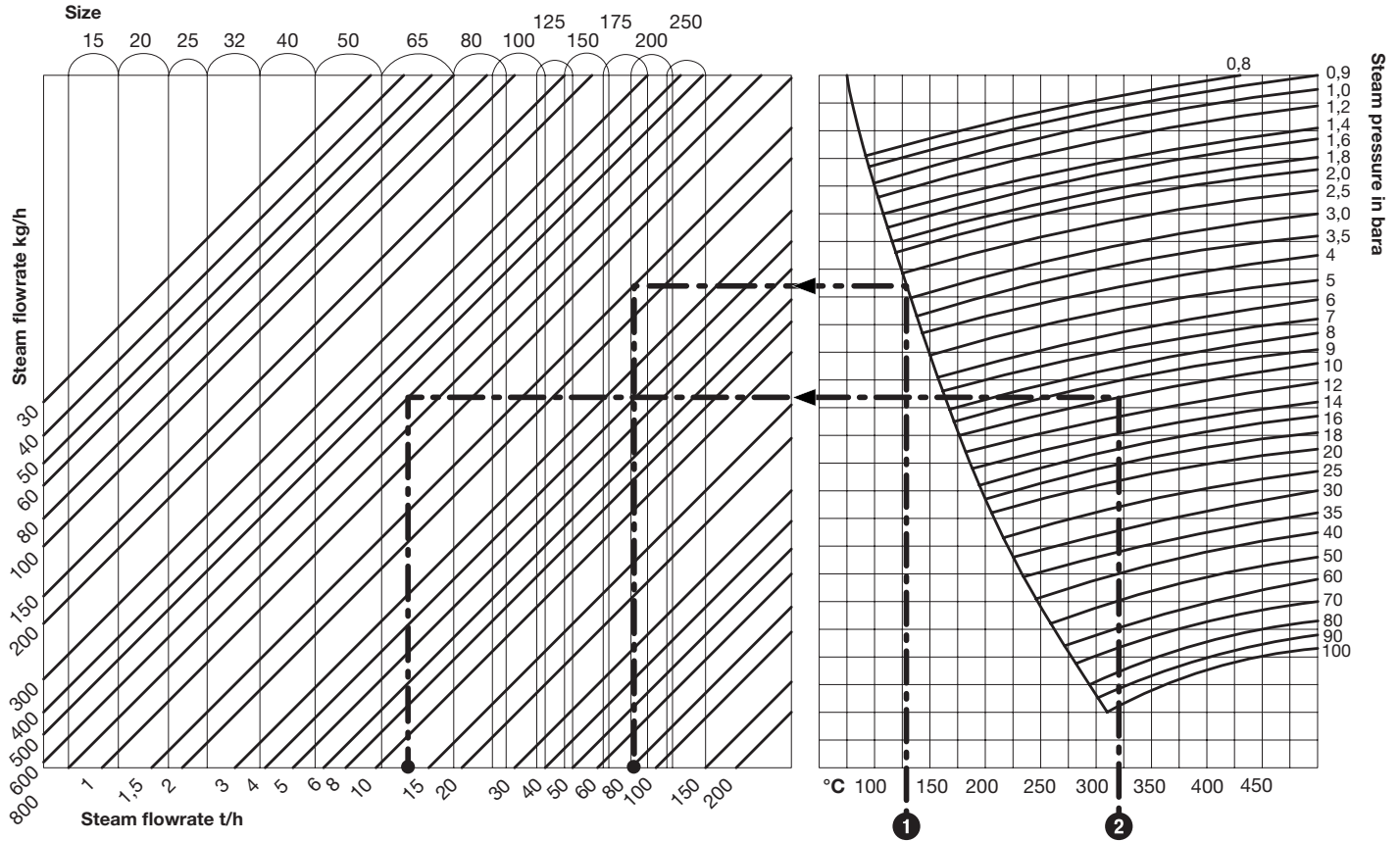

① Saturated steam 129.3°C, 2.7 bar, steam flowrate 1.5 t/h

② Superheated steam 320°C, 10 bar, steam flowrate 60 kg/h

Nominal size

The nominal size depends on the dimensions of the guide chamber which, based on operating conditions, ensures separation of optimum efficiency.

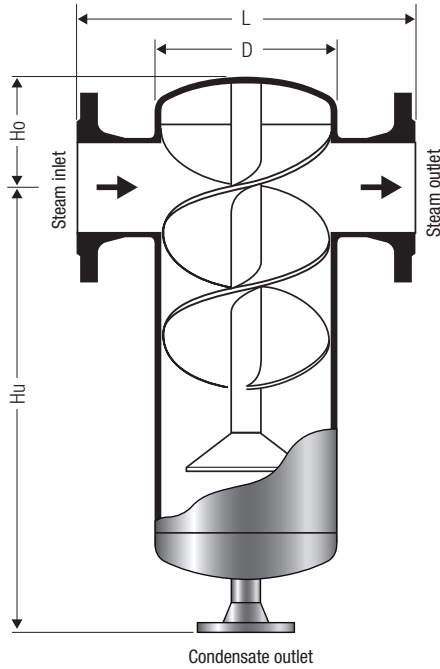

Type of end connection

Flanges to DIN EN 1092-1. ANSI flanges or socket end to DIN 10241, for an additional charge.

Maximum/minimum pressure/temp. ratings and materials for our standard equipment

Max. pressure/temp. ratings

	p bar	t °C	Material
PN 16	12	200	P235GH, P265GH, P250GH
PN 40	28	250	P235GH, P265GH, P250GH
PN 16	12	200	1.4571

Higher nominal pressure stages and/or mass flowrates are possible, depending on requirements and desired material. Higher pressure and temperature ratings are possible on request.

Surface treatment

Carbon steel: Inside: Blank
Outside: Primer
Stainless steel: Pickled and passivated

Design in accordance with the AD 2000 Code of Practice

- Without alternating stress to S1 and S2
- Without additional load to S3/6

Manufactured and tested in accordance with the Pressure Equipment Directive DGRL 97/23/EC

ATEX (Hazardous Area)

The equipment does not have a potential ignition source and is therefore not subject to the ATEX Directive 94/9/EC. Suitable for use in Ex zones 0, 1, 2, 20, 21, 22 (1999/92/EC). The equipment does not have Ex classification.

Drainage of separated liquid

To drain liquid, a GESTRA ball-float steam trap should be installed below the equipment, e.g. UNA14v, UNA16, UNA45v or UNA46.

(More detailed descriptions can be found in separate data sheets.)

Steam traps are selected on the basis of the operating data or the customer's wishes.

Special designs

Contrary to the temperature and pressure ratings specified in this data sheet, our steam drier is available in special designs (e.g. TD-LKD).

Please note our terms of sale and delivery.

Types TD, PN 16 and PN 40

Nominal size	Nominal inlet/outlet diameter Steam inlet/outlet DN	Condensate outlet DN	Inspection hole DN	Dimensions				Volume V l	Weight m kg	PN 16 Classification fluid group 2		PN 40 Classification fluid group 2	
				D mm	L mm	Hu mm	Ho mm			Module	Category	Module	Category
15	15	15		60	210	310	80	0.6	4.1	Sect. 3 (3)		Sect. 3 (3)	
20	15 20	15 15		60	220	305	85	0.7	4.8	Sect. 3 (3)		Sect. 3 (3)	
25	15 20 25	15 15 15		70	220	385	95	1.4	6.4	Sect. 3 (3)		Sect. 3 (3)	
32	20 25 32	15 15 15		70	220	375	105	1.5	7.7	Sect. 3 (3)		Sect. 3 (3)	
40	25 32 40	15 15 15		115	270	370	120	3.5	10.5	Sect. 3 (3)		A	I
50	32 40 50	15 15 15		115	270	360	130	3.7	11.8	Sect. 3 (3)		A	I
65	40 50 65	15 15 15		170	320	460	150	10.6	21.5	A	II	A1	II
80	50 65 80	15 15 15		200	360	500	160	14.7	28.3	A	II	A1	II
100	65 80 100	20 20 20		220	410	570	190	22.9	37.2	A1	II	A1	II
125	80 100 125	20 20 20		250	440	655	215	34	48.8	A1	II	A1	II
150	100 125 150	25 25 25		270	500	740	230	49	62	A1	III	G	III
175	125 150	25 25		320	560	870	240	76	83	A1	III	G	III
200	150 200	25 25	150 150	350	650	1055	285	119	118	G	III	G	IV
250	150 200 250	25 25 25	150 150 150	400	720	1170	330	178	167	G	III	G	IV

GESTRA AG

Postfach 10 54 60, D-28054 Bremen
Münchener Str. 77, D-28215 Bremen
Tel. 0049 (0) 421 35 03-0, Fax 0049 (0) 421 35 03-393
e-mail gestra.ag@flowserve.com, Web www.gestra.com



GESTRA