

Oil Detector & Alarm for Cooling Water

ORGS 11-1

ORGS 11-2

Description

Use oil detector & alarm ORGS 11-2 only for signalling ingress of oil in cooling water systems.

Function

The oil detector & alarm ORGS 11-2 is an equipment unit consisting of the measuring electrode ORGS 11-1 and a measuring pot.

The measuring electrode ORGS 11-1 is a compact-type system that comprises the measuring electrode and an electronic module integrated in the terminal box. The electrode operation is based on the conductive measuring principle using the electrical conductivity of the water for signalling water level. The electronic module detects whether the electrode rods are submerged or exposed and, in the event of ingress of oil, energises the output contacts.

A water sample, taken from the cooling water system downstream of the location at the highest point where ingress of oil might occur, is fed from below into the measuring pot of the ORGS 11-2. If the water is contaminated with oil, the oil droplets - due to their lower density - ascend and accumulate on top of the water and, consequently, the electrode rods are now submerged in this oil film.

Oil is not electrically conductive, which means that no current can flow between the electrode rods of the measuring electrode. In this case the oil detector & alarm will signal ingress of oil and trigger an alarm.

The amount of oil necessary to signal ingress of oil depends on the design of the measuring pot and the length of the electrode rods. The measuring pot is matched to the electrode such that ingress of oil is signalled when the oil content limit of approx. 50 ml is reached.

The equipment can detect all substances that are insoluble in water, not emulsified and lighter than water. In addition, the equipment can also detect all liquids with a conductivity value below the adjusted response sensitivity.

Directives and Standards

Approvals for Marine Applications

The equipment is approved for marine applications.

LV (Low Voltage) Directive and EMC (Electromagnetic Compatibility)

The equipment meets the requirements of the Low Voltage Directive 2014/35/EU and the EMC Directive 2014/30/EU.

ATEX (Atmosphère Explosible)

According to the European Directive 2014/34/EU the equipment must **not** be used in potentially explosive areas.

Design

ORGS 11-2:

Equipment module with three isolating valves and deaerator, ready for connection.

ORGS 11-1:

Measuring electrode as spare part for equipment module ORGS 11-2

Technical Data

Oil detector & alarm ORGS 11-2

Service pressure

6 bar

Service temperature

110 °C

Technical Data - continued -

Flow velocity

100 l/h to 300 l/h, recommended 200 l/h

Pressure drop Δp_v

0.06 bar (under test conditions)

Alarm

Raised when approx. 50 ml oil has accumulated

Water inlet, drain

Ball valve with EO-connection 15L

Water outlet

Ball valve with EO-connection 12L

Weight

approx. 7.4 kg

Measuring electrode ORGS 11-1

(component of ORGS 11-2)

Mechanical connection

Screwed G 1 A, ISO 228

Materials

Screw-in body: 1.4571, X6CrNiMo17-12-2

Electrode rods: 1.4571, X6CrNiMo17-12-2

Terminal box: 3.2161 G AISi8Cu3

Supply voltage

230 V +/- 10 %, 50/60 Hz

115 V +/- 10 %, 50/60 Hz

24 V +/- 10 %, 50/60 Hz (optional)

Power consumption

5 VA

Fuse

external slow-blow 0.5 A

internal thermal fuse $T_{max} = 102 °C$

Response sensitivity

Range 1: 10 $\mu S/cm$

Range 2: 0.5 $\mu S/cm$

Code-switch selectable

Electrode voltage

10 V_{pp}

Outputs for control circuit

2 volt-free change-over contacts,

8 A 250 V AC / 30 V DC $\cos \phi = 1$

De-energizing delay: 3 sec.

Provide inductive loads with RC combinations according to manufacturer's specification to ensure interference suppression.

Indicators and adjusters

2 red LEDs indicating "Electrode submerged" and "Output relay energized" (no ingress of oil)

1 four-pole code switch for selecting the response sensitivity

Electrical connection

2 cable gland with integrated cable clamp M20 x 1.5

1 five-pole screw-type terminal strip, detachable, conductor size 1.5 mm²

Protection

IP 65 to DIN EN 60529

Max. admissible ambient temperature

Max. 70 °C

Storage and transport temperature

- 40 up to + 80 °C

Certification

Marine applications

BV 17515-B0 BV

GL 17106-00 HH;

LR 07-20031 (E1)

Oil Detector & Alarm for Cooling Water

ORGS 11-1

ORGS 11-2

Important Notes

Rust preventing oils, which are for instance emulsified in the cooling water, will not raise an alarm!

Installation

- The water sample taken from the cooling water system must flow continuously through the oil detector & alarm ORGS 11-2. We recommend a flowrate of 200 l/h.
- The sampling of the cooling water should take place downstream of a potential oil leak at the highest point and, if possible, in a horizontal line. Since the oil flows in the upper part of the pipe we recommend the installation of a welding saddle according to DIN 2618 for collecting the oil droplets. The line leading to the measuring pot of the ORGS 11-2 should be vertically ascending, running directly into the bottom part of the measuring pot. Avoid any narrow parts in the supply line since they could give rise to undesired emulsification of the oil.
- If space is a consideration and the measuring pot has to be installed at a lower point than the main cooling line make sure that the line leading to the measuring pot features sufficiently sized bends in order to prevent emulsification.
- To achieve the recommended flowrate of approx. 200 l/h provide the main cooling water line with a standard orifice plate in order to throttle the flow velocity between the water sampling location and its re-entry point. The pressure drop Δp_v in the measuring pot is 0.06 bar.
- The pressure drops of the connecting lines depend on the design and layout of the installation and must be ascertained individually. The calculated resistance coefficient ζ can be used to determine the opening ratio and, consequently, the required diameter "d" for the opening of the standard orifice plate. For more information on the sizing and layout of fluid dynamic systems please refer to the corresponding technical literature and relevant standards.

Electrical connection

- The oil detector & alarm must be provided with an external slow-blow fuse 0.5 A. To connect the supply voltage and the output contacts use multi-core control cables with a min. conductor size 1.5 mm², e. g. LiYCY .. x 1.5 mm².

Order & Enquiry Specification

GESTRA Oil detector & alarm for cooling water
ORGS 11-2, PN 6

Supply voltage

Supply in accordance with our general terms of business.

Dimensions

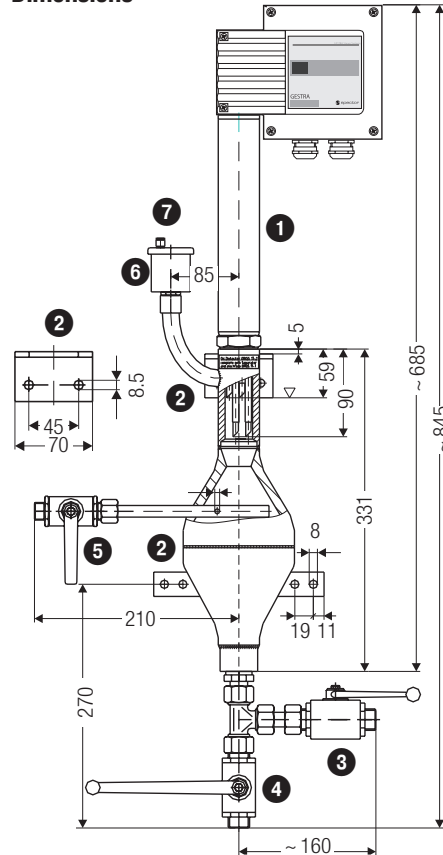

Fig. 1 ORGS 11-2

Examples of installation

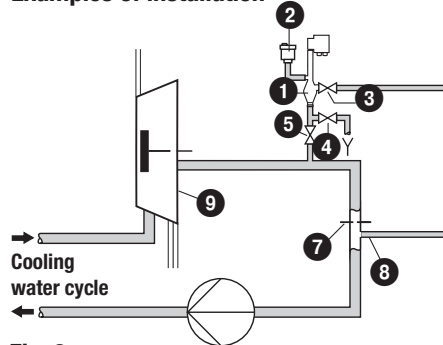

Fig. 3

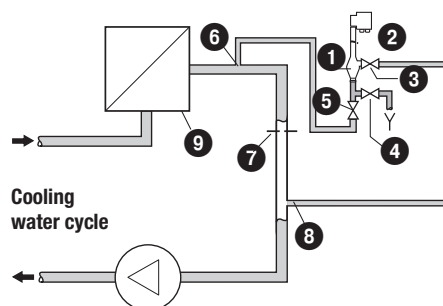

Fig. 4

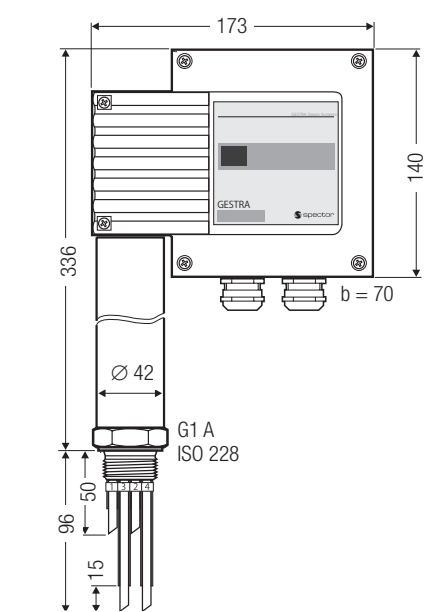

Fig. 2 ORGS 11-1

Electrical connection

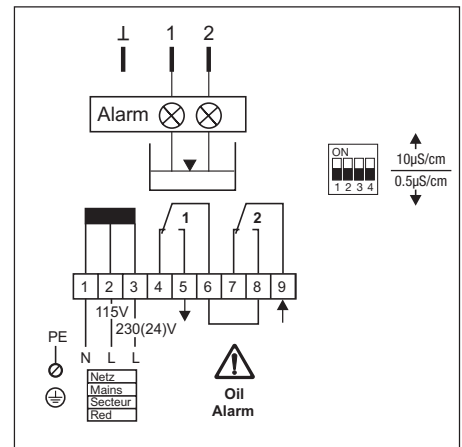

Fig. 5

Key

- 1 Measuring electrode ORGS 11-1
- 2 Support flange
- 3 Drain (ball valve DN 15 L, PN 500)
- 4 Cooling water inlet (ball valve DN 15 L, PN 500)
- 5 Cooling water outlet (ball valve DN 12 L, PN 500)
- 6 Deaerator
- 7 Sealing plug with lateral vent hole
- 8 Oil detector & alarm ORGS 11-2
- 9 Cooling water outlet DN 12 (outside Ø 16 mm)
- 10 Standard orifice plate
- 11 Cooling water inlet DN 15 (outside Ø 20 mm)
- 12 Main engine, diesel fuel, oil cooler, etc.

GESTRA AG

Münchener Straße 77, 28215 Bremen, Germany
Telefon +49 421 3503-0, Telefax +49 421 3503-393
E-mail info@de.gestra.com, Web www.gestra.de

