

Steam Trap

BK 27N

EN
English

Original Installation Instructions
818627-02

Contents

Preface	3
Availability.....	3
Text layout.....	3
Safety	3
Usage for the intended purpose.....	3
Basic safety notes.....	4
Typographic features of warning notes.....	5
Typographic features of information on environmental & property damage.....	5
Description	5
Scope of supply and equipment specification.....	5
Purpose and function.....	8
Storing and transporting the equipment	8
Storing the equipment.....	8
Transporting the equipment.....	9
Mounting and connecting the equipment	9
Preparing installation.....	9
Connecting the equipment.....	9
Operation	10
Activities during operation.....	10
After operation	10
Changing the settings of the Thermovit regulator.....	11
Removing external dirt deposits.....	12
Maintaining the equipment.....	12
Servicing the equipment and installing spare parts.....	12
Troubleshooting	16
Putting the equipment out of operation	19
Removing harmful substances.....	19
Removing the equipment.....	19
Re-using equipment after storage.....	20
Disposing of the equipment.....	20
Technical data	21
Dimensions and weights.....	21
Limiting conditions.....	22
Manufacturer's Declaration	23

Preface

This installation & operating manual will help you use the following types of equipment safely and efficiently for their intended purpose.

- ▶ BK 27N, PN 40
- ▶ BK 27N, PN 63

These steam traps will be called equipment in this document.

This installation & operating manual is intended for anyone commissioning, using, operating, servicing, cleaning or disposing of this equipment and, in particular, for professional after-sales service technicians, qualified personnel and authorised and trained staff.

All of these persons must read and understand the content of this installation & operating manual.

Following the instructions given in this installation & operating manual helps avoiding danger and increases the reliability and service life of the equipment. Please note that in addition to the instructions given in this installation & operating manual you must also observe all locally applicable rules and regulations concerning the prevention of accidents as well as approved safety guidelines for good professional practice.

Availability

Keep this installation & operating manual together with the plant documentation for future reference. Make sure that this installation & operating manual is available to the operator.

The installation & operating manual is part of the equipment. Please hand over this installation & operating manual when selling the equipment or passing it on.

Text layout

Certain text elements of this installation & operating manual feature a specific typographic design. You can easily distinguish the following text elements:

Standard text

Cross-reference

- ▶ Listing
 - ▶ Sub-items in listings
- Steps for action.



Here you will find additional useful information and tips serving to assist you in using the equipment to its fullest potential.

Safety

Usage for the intended purpose

The following thermostatic/thermodynamic steam traps are installed in steam lines:

- ▶ BK 27N, PN 40
- ▶ BK 27N, PN 63

This equipment is designed for discharging condensed water or air-venting pipes.

The equipment must only be used within the allowable pressure and temperature limits and only if the chemical and corrosive influences on the equipment are taken into account.

Correct use includes compliance with the instructions given in this installation & operating manual, in particular obedience to all safety instructions.

Any other use of the equipment is considered to be improper.

Note that the equipment is also used incorrectly if the materials of the equipment are not suitable for the fluid.

Basic safety notes

Risk of severe injuries

- ▶ The equipment is under pressure during operation and may be hot. Before carrying out any work on the equipment make sure that the following requirements are met:
 - ▶ The pipes must be depressurized (0 bar).
 - ▶ The fluid must be completely removed from the pipes and the equipment.
 - ▶ During work on the equipment the installation must be switched off and protected against unauthorised or unintended activation.
 - ▶ The pipes and the equipment must have cooled down to room temperature (approx. 20 °C).
- ▶ If the equipment is used in contaminated areas there is a risk of severe injuries or death caused by harmful substances in or on the equipment. Before working on the equipment make sure that it is completely decontaminated. Always wear the protective clothing prescribed for contaminated areas when working on the equipment.
- ▶ The equipment must only be used with fluids that do not attack the material and the gaskets and sealings of the equipment. Otherwise leaks may occur and hot or toxic fluid could escape.
- ▶ The equipment and its component parts must only be mounted or removed by qualified personnel. A qualified person must be acquainted with and experienced in the following:
 - ▶ Making pipe connections.
 - ▶ Selecting suitable lifting gear and understanding the rules for its safe use.
 - ▶ Working with dangerous (contaminated, hot or pressurized) fluids.

Risk of minor injuries

- ▶ Sharp edges on internals present the danger of cuts to hands. Always wear industrial gloves when servicing the equipment.
- ▶ If the support of the equipment during installation is insufficient the equipment might fall down, thereby causing bruises or injuries. Make sure the equipment is safely held in place during installation and cannot fall down. Wear protective safety footwear.

Risk of property damage or malfunctions

- ▶ Malfunctions will occur if the equipment is installed in a wrong position or with the flow arrow pointing in the opposite direction of the fluid flow. This may result in damage to the equipment or the installation. Make sure that the flow arrow on the equipment body matches the indicated direction of the fluid flow in the pipe.
- ▶ If the material is unsuitable for the fluid, increased wear may occur and fluid may escape. Make sure that the material is suitable for the fluid used in your installation.

Typographic features of warning notes



DANGER

Notes with the heading DANGER warn against imminent dangerous situations that can lead to death or serious injuries.



WARNING

Notes with the heading WARNING warn against possibly dangerous situations that could lead to death or serious injuries.



CAUTION

Notes with the heading CAUTION warn against dangerous situations that could lead to minor or moderate injuries.

Typographic features of information on environmental & property damage

Attention!

This note warns against situations that may lead to environmental and/or property damage.

Description

Scope of supply and equipment specification

Scope of supply

Our equipment is delivered packed and ready for assembly.

Equipment specification

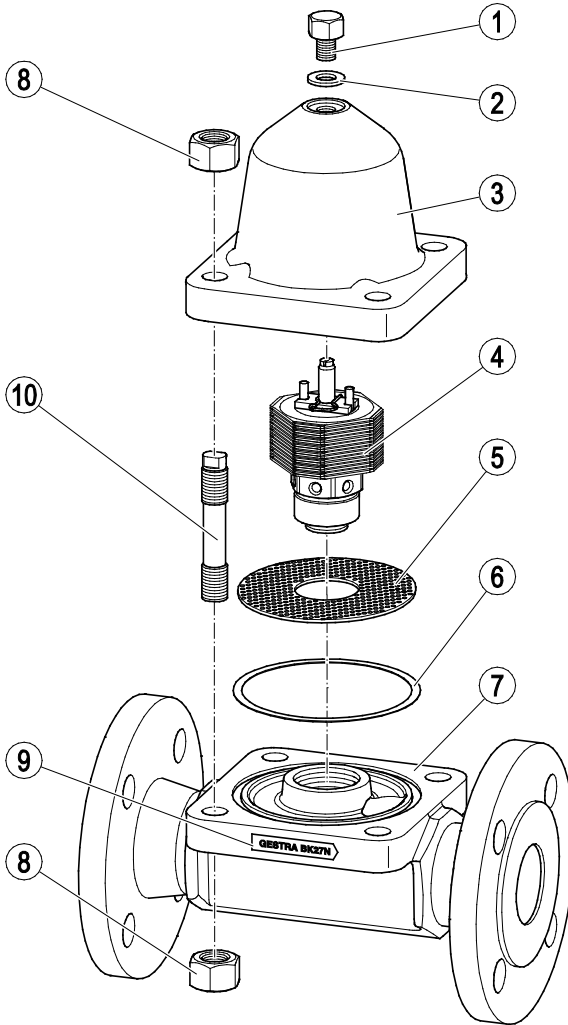

No.	Designation
1	Sealing plug
2	Gasket for sealing plug
3	Cover
4	Thermovit regulator
5	Strainer

No.	Designation
6	Gasket
7	Body
8	Eight nuts
9	Name plate
10	Four stud bolts

Optional extras

The following add-on equipment is available:

- ▶ Ultrasonic test device VAPOPHONE®
- ▶ Continuous condensate monitoring equipment



Continuous condensate monitoring is only available up to PN 40.

End connections

The equipment is available with the following end connections:

- ▶ Flanges
- ▶ Butt-weld ends
- ▶ Socket-weld ends

Name plate

The following items are indicated on the name plate:

- ▶ Manufacturer
- ▶ Type designation
- ▶ Code letter for opening temperature of Thermovit regulator (only if different from standard value)
- ▶ Nominal size
- ▶ Pressure rating
- ▶ Max. admissible differential pressure
- ▶ Direction of flow
- ▶ CE marking

The following items are indicated on the equipment body:

- ▶ Material
- ▶ Batch code
- ▶ Manufacturing date (quarter/year)



Equipment with flanged ends has the manufacturing date indicated on the flange.

The following items are indicated on the end connections:

- ▶ Flange size
- ▶ Flange face type (RJ number)

Application of European Directives

Pressure Equipment Directive

The equipment conforms to this directive (see "Manufacturer's Declaration" section) and can be used for the following media:

- ▶ Fluids of group 2

ATEX Directive

The equipment does not have its own potential ignition source and is not subject to this directive (see "Manufacturer's Declaration" section).

When installed, static electricity may arise between the equipment and the connected system.

When used in potentially explosive atmospheres, the plant manufacturer or plant operator is responsible for discharging or preventing possible static charge.

If it is possible for medium to escape, e.g. through actuating mechanisms or leaks in threaded joints, the plant manufacturer or plant operator must take this into consideration when dividing the area into zones.

Purpose and function

Purpose

This equipment is designed for discharging condensed water or air-venting steam lines.

The equipment features integral non-return valve action.

Function of the Thermovit controller

The equipment is fitted with a Thermovit regulator that regulates the flow of the fluid. The Thermovit regulator is screwed into the body.

The Thermovit regulator consists of a stack of several bimetallic plates. As the fluid temperature rises the plates deflect, thereby moving the stage nozzle. The orifice is being closed.

When the installation is cold the Thermovit regulator is open.

You can change the Thermovit regulator settings so that the trap opens or closes at higher or lower temperatures.

In the event of backflow, the pressure of the fluid forces the nozzle stem into the nozzle support. As a result the orifice is being closed.

Storing and transporting the equipment

Attention!

Equipment can be damaged if stored or transported improperly.

- Close all openings with the sealing plugs or covers supplied with the equipment or use similar sealing covers.
- Protect the equipment against moisture and corrosive atmospheres.
- Please contact the manufacturer if the specified transport and/or storage requirements cannot be met.

Storing the equipment

- Please observe the following items when storing the equipment:
 - Do not store the equipment for more than 12 months.
 - Use the supplied sealing plugs or other suitable seal caps in order to seal off all openings of the equipment.
 - Protect the sealing surfaces and contact areas against mechanical damage.
 - Protect the equipment and all components against hard shocks and impacts.
 - Store the equipment only in closed rooms that meet the following environmental conditions:
 - Air humidity below 50 %, not condensing
 - Indoor air: clean, salt-free and non-corrosive
 - Temperature 5–40 °C.
- Make sure that all these requirements are always met when storing the equipment.
- Please contact the manufacturer if you cannot comply with the recommended storage conditions.

Transporting the equipment

- Meet the requirements for storage also when transporting the equipment.
- Prior to transport seal off connections with sealing plugs.



If you do not have the sealing plugs supplied with the equipment use appropriate seal caps to seal off the connections.

- For short distances (only a few metres) you can transport the equipment unpacked.
- When transporting the equipment over larger distances use the original packaging.
- If you do not have the original packaging use a box that protects the equipment adequately against corrosion and physical damage.



For a short period of time the equipment may be transported even if the temperature is below 0 °C, provided that the equipment is completely empty and dry.

Mounting and connecting the equipment

Preparing installation

- Take the equipment out of the transport packaging.
- Check the equipment for transport damage.
- Contact the manufacturer if you detect any kind of shipping damage.

When supplied by the factory, the connections may be sealed off with sealing plugs.

- Remove sealing plugs before mounting the equipment.
- Keep the sealing plugs and the packing for further use.



DANGER

Personnel working on pipes are exposed to safety risks and may suffer severe injuries, poisoning or even loss of life.

- Make sure that no hot or hazardous fluid is in the equipment or the pipes.
- Make sure that the pipes upstream and downstream of the equipment are depressurised.
- Make sure that the installation is switched off and protected against unauthorised or unintended activation.
- Make sure that the equipment and the pipes have cooled down to room temperatures.
- Wear protective clothing that is suitable for the fluid and, if necessary, wear protective gear.

For more information on suitable safety clothing and safety gear refer to the safety data sheet of the fluid in question.

- Drain pipes until they are empty.
- Switch the installation off and protect it against unauthorised or unintended re-activation.

Connecting the equipment



DANGER

Incorrectly connected equipment can cause fatal accidents or severe injuries.

- Make sure that only qualified skilled personnel connect the equipment to pipes.
- Make sure that the flow arrow on the equipment body matches the direction of flow in the pipe.

Specialist personnel must be highly qualified and fully experienced in making pipe connections for the respective type of end connection.

Attention!

Equipment will be damaged if the end connections are undersized.

- Make sure that the connections are strong and rigid enough to support the weight of the equipment and to withstand the forces that occur during operation.

To allow easy access for routine servicing and exchanging components observe the indicated withdrawal distances and allow for clearances to adjacent installation parts.

For more information see chapter "*Dimensions and weights*" on page 21.

- Make sure that the pipe system of the plant is clean.

The equipment can be installed in any position.

If the equipment is installed in a horizontal line the cover should be on top.

- Make sure that the equipment is free from foreign matter.
- Mount the equipment in the desired installation position.
- Make sure that the equipment is safely mounted and that all connections are made correctly.

Attention!

Malfunions may occur if the equipment or condensate line is insulated.

- Make sure that the heat generated by the equipment or the condensate line is dissipated.
-

Operation

Activities during operation

During operation you cannot change the settings of the Thermovit regulator.

You can check the equipment for correct operation using the GESTRA ultrasonic measuring unit VAPOPHONE®.

- For more details refer to the installation & operating manual of the ultrasonic measuring unit.

Continuous steam trap monitoring is recommended for critical applications.

- For more details refer to the installation & operating manual of the continuous steam trap monitoring unit.

After operation



DANGER

If the equipment is used in contaminated areas there is a risk of severe injuries or death caused by harmful substances in or on the equipment.

- Only qualified personnel are allowed to perform work on contaminated equipment.
 - Always wear the protective clothing prescribed for contaminated areas when working on the equipment.
 - Make sure that the equipment is completely decontaminated before carrying out any service work.
 - Follow the pertinent instructions for handling the hazardous substances in question.
-

Attention!

Frost damage may occur when the installation is shut down.

- Drain the equipment if ambient temperatures below 0 °C (frost) are to be expected.

Changing the settings of the Thermovit regulator

You can change the temperature setting for the opening or closing of the Thermovit regulator.

You can increase or decrease the temperature by 48 K. For this purpose proceed as follows:



DANGER

Personnel working on pipes are exposed to safety risks and may suffer severe injuries, poisoning or even loss of life.

- Make sure that no hot or hazardous fluid is in the equipment or the pipes.
- Make sure that the pipes upstream and downstream of the equipment are depressurised.
- Make sure that the installation is switched off and protected against unauthorised or unintended activation.
- Make sure that the equipment and the pipes have cooled down to room temperatures.
- Wear protective clothing that is suitable for the fluid and, if necessary, wear protective gear.

For more information on suitable safety clothing and safety gear refer to the safety data sheet of the fluid in question.

Preparing the adjustment

- Remove the sealing plug (1) and the gasket (2).
- Put a screwdriver into the slot of the nozzle stem (11).

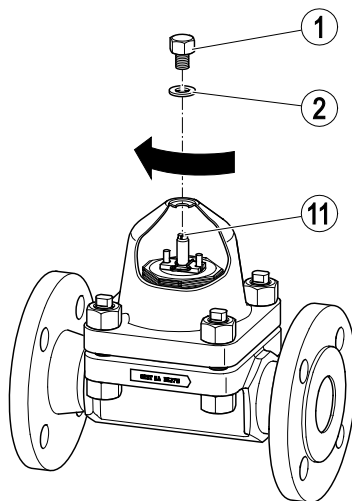

Setting for more undercooling

You can reduce the factory-set opening temperature by up to 48 K. This corresponds to 1 ½ clockwise turns of the nozzle stem.

- To reduce the opening temperature by 8 K turn the screwdriver by 1/4 clockwise.

Setting for less undercooling

You can increase the factory-set opening temperature by up to 48 K. This corresponds to 1 ½ anticlockwise turns of the nozzle stem.

- To increase the opening temperature by 8 K turn the screwdriver by 1/4 anticlockwise.



If the undercooling is too low steam may escape.

Restoring factory setting

To reset the regulator to its factory-set opening temperature proceed as follows:

- Turn the screwdriver clockwise until the stop is felt.
- Then turn the screwdriver anticlockwise by 3 ¼ turns.

Finishing the adjustment

- Put the gasket (2) into the cover (3).
- Screw the sealing plug (1) into the cover.
- Tighten the sealing plug with a torque of 40 Nm.

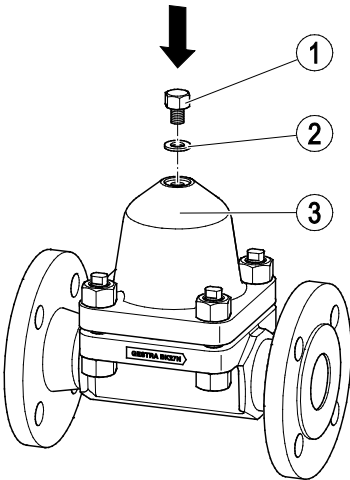

- Check the adjustment
- If the setting is not correct repeat the adjustment procedure.

Removing external dirt deposits

- To remove dirt deposits rinse the equipment with fresh water and wipe it with a clean, lint-free cloth.
- To remove any persistent residues use a cleaning agent that is suitable for the material and carefully wipe the equipment with a clean, lint-free cloth.

Maintaining the equipment

The equipment is maintenance-free.

Servicing the equipment and installing spare parts

You may exchange the following component parts in case of wear or damage:

- Thermovit regulator
- Strainer
- Sealing plug
- Gasket
- Gasket

To disassemble the equipment use the following tools:

- Combination spanner A. F. 41
- Combination spanner A. F. 27
- Combination spanner A. F. 19
- Combination spanner A. F. 10

Spare Parts

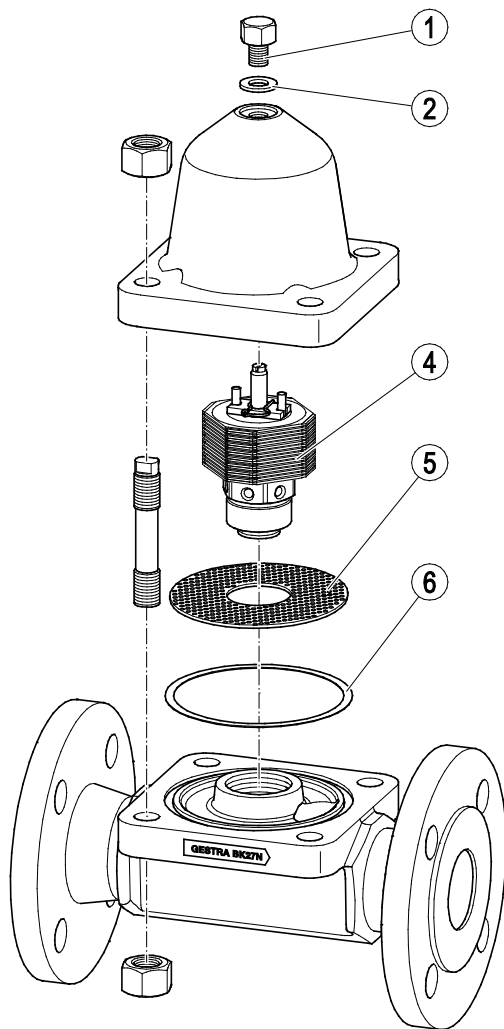

No.	Designation	Stock code #
1	Sealing plug	096178
2	Gasket for sealing plug	000992
4, 6	Thermovit regulator ¹ , complete with gasket	376607
5	Strainer	097018
6	Seal ²	376677

1 The Thermovit regulator does not fit into the body of the BK 27.

2 Minimum purchasing quantity 20 pcs. Contact your local dealer for smaller quantities.

Removing Thermovit regulator

To clean the Thermovit regulator and, if necessary, replace it with a new one proceed as follows:

- Loosen the nuts (8) on the stud bolts.
- Remove the stud bolts (10).
- Lift the cover (3) off the body (7).
- Remove the gasket (6).
- Use an open-end spanner (US: wrench) to unscrew the Thermovit regulator (4) from the body.
- Remove the strainer (5).

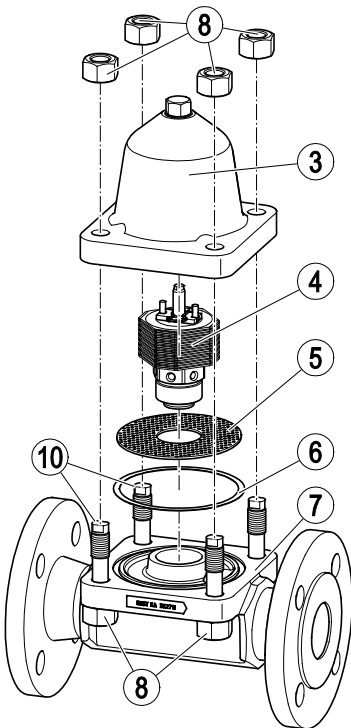

Cleaning Thermovit regulator

- Clean the Thermovit regulator with fresh water and a clean lint-free cloth.
- Clean gasket seating surfaces.

Checking the component parts for damage

- Check the removed parts for visible signs of wear or damage.
- Discard and replace any damaged part.

Installing Thermovit regulator

To fit the Thermovit regulator proceed as follows:

- Apply heat-resistant lubricant to the following surfaces:
 - all threads
 - the seating surface of the nozzle insert
- If the gasket is damaged replace it with a new one.
- Put the strainer and the gasket into the body.
- Screw the Thermovit regulator with a torque of 350 Nm into the body.
- Put the cover onto the body.
- Use the stud bolts and the nuts to fix the cover to the body.
- Tighten the nuts on the stud bolts in diagonally opposite pairs to a torque of 90 Nm.

Removing and cleaning the strainer

To replace the strainer proceed as follows:

- Remove the Thermovit regulator as described in section "Removing Thermovit regulator" from page 14 onwards.
- Take out the strainer.
- Clean the gasket and the strainer with fresh water and a clean lint-free cloth.
- Clean gasket seating surfaces.

Checking the component parts for damage

- Check the removed parts for visible signs of wear or damage.
- Discard and replace any damaged part.

Mounting the strainer

- Apply heat-resistant lubricant to the threads.
- If the gasket is damaged replace it with a new one.
- Put the strainer and the gasket into the body.
- Screw the Thermovit regulator with a torque of 350 Nm into the body.
- Put the cover onto the body.
- Use the stud bolts and the nuts to fix the cover to the body.
- Tighten the nuts on the stud bolts in diagonally opposite pairs to a torque of 90 Nm.

Troubleshooting

Problem	Cause	Remedy
The steam trap is cold or only hand-hot.	The shut-off valves for condensate inlet or outlet are closed.	Open the isolating valves.
	The condensate inlet or outlet is dirt clogged.	Clean the pipes. Clean the equipment.
The steam trap is blowing off live steam.	The Thermovit regulator is contaminated. There are dirt deposits in the equipment.	Clean the Thermovit regulator. Clean the strainer and the equipment. Replace the Thermovit regulator with a new one.
	The Thermovit regulator is worn down. The seat is leaking.	Replace the Thermovit regulator with a new one.
	The bypass is open.	Close the bypass.
Fluid escapes (equipment is leaking).	The end connections are not tight.	Seal off the end connections (e. g. flanged or screwed ends).
	A gasket on the body is defective.	Replace the gasket with a new one.
	The body has been damaged by corrosion or erosion.	Check the resistance of the material for the fluid used. Use a steam trap made from a material that is suitable for the fluid used.
	The equipment has been damaged by frost.	Replace the equipment with a new one. When shutting down the installation make sure that the condensate lines and the steam trap are completely drained.
	The equipment has been damaged by waterhammer.	Replace the equipment with a new one. Take appropriate measures to protect the equipment against waterhammer, e. g. by installing suitable non-return valves.

Problem	Cause	Remedy
<p>Insufficient condensate discharge.</p> <p>Insufficient thermal output of the user.</p>	The shut-off valves for condensate inlet or outlet are closed.	Open the isolating valves.
	The condensate inlet or outlet is dirt clogged.	Clean the pipes. Clean the equipment.
	Steam pressure and condensate flowrate fluctuate considerably. The pressure upstream of the steam trap is too low for the used trap type.	Use a different steam trap type. Contact the manufacturer to find out which trap type is the most suitable for your application.
	The steam trap is undersized.	Use a steam trap with a larger condensate discharge capacity.
	The differential pressure is too small.	Increase the steam pressure. Lower the pressure in the condensate line. Check the size of the condensate line. Install a steam trap with a larger condensate discharge capacity, a pump steam trap or a condensate return unit.
	The pressure upstream of the steam trap is too low. The pressure in the condensate line is too high.	Use a different steam trap type. Contact the manufacturer to find out which trap type is the most suitable for your application.
	The distance between the drain point and the steam trap is too small.	Install the steam trap approx. 1 - 2 m away from the drain point. Lay the condensate line with a gradient so that the condensate is free to fall towards the steam trap.
	The condensate line does not have a slight fall from the drain point towards the steam trap. The condensate is lifted upstream of the steam trap.	Lay the condensate line with a gradient so that the condensate is free to fall towards the steam trap. Change the orientation of the condensate line.

Problem	Cause	Remedy
	<p>The condensate temperature is higher than the service temperature of the steam trap.</p> <p>The Thermovit regulator does not open or only with a time delay.</p>	<p>If the steam trap or the condensate line is insulated remove the insulation.</p> <p>Use a different steam trap type.</p> <p>Contact the manufacturer to find out which trap type is the most suitable for your application.</p>
	<p>Insufficient deaeration.</p>	<p>Provide additional deaeration.</p> <p>Use a different steam trap type.</p> <p>Contact the manufacturer to find out which trap type is the most suitable for your application.</p>

- If faults occur that are not listed above or cannot be corrected, please contact our Technical Service or authorized agency in your country.

Putting the equipment out of operation

Removing harmful substances



DANGER

If the equipment is used in contaminated areas there is a risk of severe injuries or death caused by harmful substances in or on the equipment.

- Only qualified personnel are allowed to perform work on contaminated equipment.
- Always wear the protective clothing prescribed for contaminated areas when working on the equipment.
- Make sure that the equipment is completely decontaminated before carrying out any service work.
- Follow the pertinent instructions for handling the hazardous substances in question.

Qualified personnel must have extensive experience with and a working knowledge of:

- ▶ pertinent rules and regulations concerning handling hazardous substances
- ▶ special regulations for handling the hazardous substances encountered on site
- ▶ using the required personal protective equipment (PPE) and clothing

Attention!

Environmental damage may be caused by poisonous fluid residues.

- Before disposing of the equipment make sure that it is clean and free of fluid residues.
- For the disposal of all materials observe the pertinent legal regulations concerning waste disposal.

- Remove all residues from the equipment.
- For the disposal of all residues observe the pertinent legal regulations concerning waste disposal.

Removing the equipment



DANGER

Personnel working on pipes are exposed to safety risks and may suffer severe injuries, poisoning or even loss of life.

- Make sure that no hot or hazardous fluid is in the equipment or the pipes.
- Make sure that the pipes upstream and downstream of the equipment are depressurised.
- Make sure that the installation is switched off and protected against unauthorised or unintended activation.
- Make sure that the equipment and the pipes have cooled down to room temperatures.
- Wear protective clothing that is suitable for the fluid and, if necessary, wear protective gear.

For more information on suitable safety clothing and safety gear refer to the safety data sheet of the fluid in question.



CAUTION

Danger of bruising if the equipment falls down.

- When removing the equipment make sure the it is safely held in place and cannot fall down.

Suitable measures are for instance:

- ▶ Equipment that is not too heavy may be supported by a second person.
- ▶ For heavy equipment use suitable lifting equipment of sufficient strength.
- Detach the end connections of the equipment from the pipes.
- Put the equipment onto a suitable base.
- Store the equipment as described in section "Storing the equipment" on page 8.

Re-using equipment after storage

Observe the following instructions if you want to remove the equipment and use it again somewhere else:

- ▶ Make sure that the equipment is free of any fluid residues.
- ▶ Make sure that all connections are in good condition and leak-free.
- ▶ If necessary re-work welded connections in order to ensure that they are in good working condition.
- Use the equipment only for its intended purpose and the service conditions for which it was specified.

Disposing of the equipment

Attention!

Environmental damage may be caused by poisonous fluid residues.

- Before disposing of the equipment make sure that it is clean and free of fluid residues.
- For the disposal of all materials observe the pertinent legal regulations concerning waste disposal.

The equipment is made from the following materials:

Component	DIN / EN	ASME
Body and cover	1.5415	A182F1
Stud bolts, nuts, sealing plug	1.7709	–
Gasket for sealing plug	1.4301	
Gasket	Graphite/CrNi	
Thermovit regulator	Stainless steel	
Other internals	Stainless steel	



The equivalent ASME material specifications are stated for guidance only. Physical and chemical properties of the materials can therefore differ from the ASME specification for materials.

- For more details please contact the manufacturer.

Technical data

Dimensions and weights

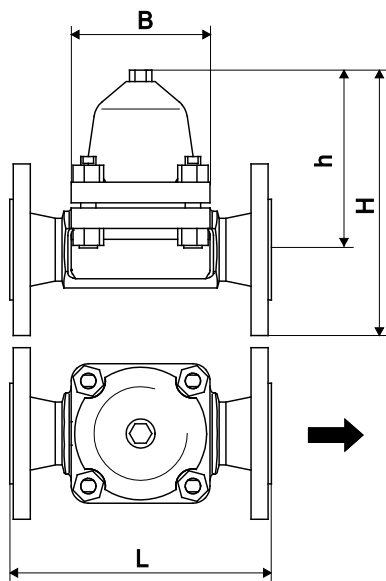

All types of equipment

	Dimension [mm]
Height h	157
Overall height H ¹	192
Width of cover B	124
Space required for servicing cover	100
Space required for servicing sealing plug	30

- ¹ Overall height of equipment with flanged ends. The overall height of equipment with other end connections is smaller.

Equipment with flanged ends

	EN PN 40		EN PN 63		ASME Class 400 RF	
	40	50	40	50	40	50
Nominal size [mm]	40	50	40	50	40	50
Nominal size [inch]	1 ½	2	1 ½	2	1 ½	2
Length L [mm]	230		260	300	241	292
Weight [kg]	15.7		17.5	18.5	20.0	21.0

Equipment with socket-weld and butt-weld ends

	Socket-weld ends		Butt-weld ends	
	40	50	40	50
Nominal size [mm]	40	50	40	50
Nominal size [inch]	1 ½	2	1 ½	2
Length L [mm]	180	260 ¹	180	180
Weight [kg]	9.0			

- ¹ With pipe ends

Limiting conditions

Equipment with flanged ends

End connection	Flanged PN 40, EN 1092-1:2013					
p (service pressure) [bar]	40.0	39.0	34.2	32.3	17.7	8.9
T (inlet temperature) [°C]	-10 to +20	250	300	350	500	530
Differential pressure Δ PMX [bar]	40					

End connection	Flanged PN 63, EN 1092-1:2013, ASME Class 400 RF						
p (service pressure) [bar]	63.0	61.5	54.0	51.0	34.1	25.7	13.0
T (inlet temperature) [°C]	-10 to +20	250	300	350	480	500 ¹	530 ¹
Differential pressure Δ PMX [bar]	45						

1 Note that values are lower from 480 °C on.

Manufacturer's Declaration

For more information on the Conformity Assessment according to European rules refer to our Declaration of Conformity or our Declaration by Manufacturer.

To download the current Declaration of Conformity or Declaration by Manufacturer go to www.gestra.com/documents or contact:

GESTRA AG

Münchener Straße 77

28215 Bremen

Germany

Telefon +49 421 3503-0

Telefax +49 421 3503-393

E-Mail info@de.gestra.com

Web www.gestra.de

This declaration is no longer valid if modifications are made to the equipment without consultation with us.



Agencies all over the world: www.gestra.de

GESTRA AG

Münchener Straße 77

28215 Bremen

Germany

Telefon +49 421 3503-0

Telefax +49 421 3503-393

E-Mail info@de.gestra.com

Web www.gestra.de

818627-02/07-2017 kx_mm (803346-03) © GESTRA AG Bremen Printed in Germany