

DN 15 – 100

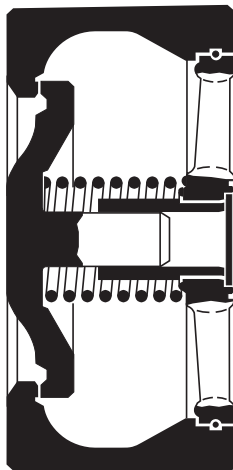

DN 125 – 200

# GESTRA Information A 2.2

## DISCO Non-Return Valves RK Examples of Application

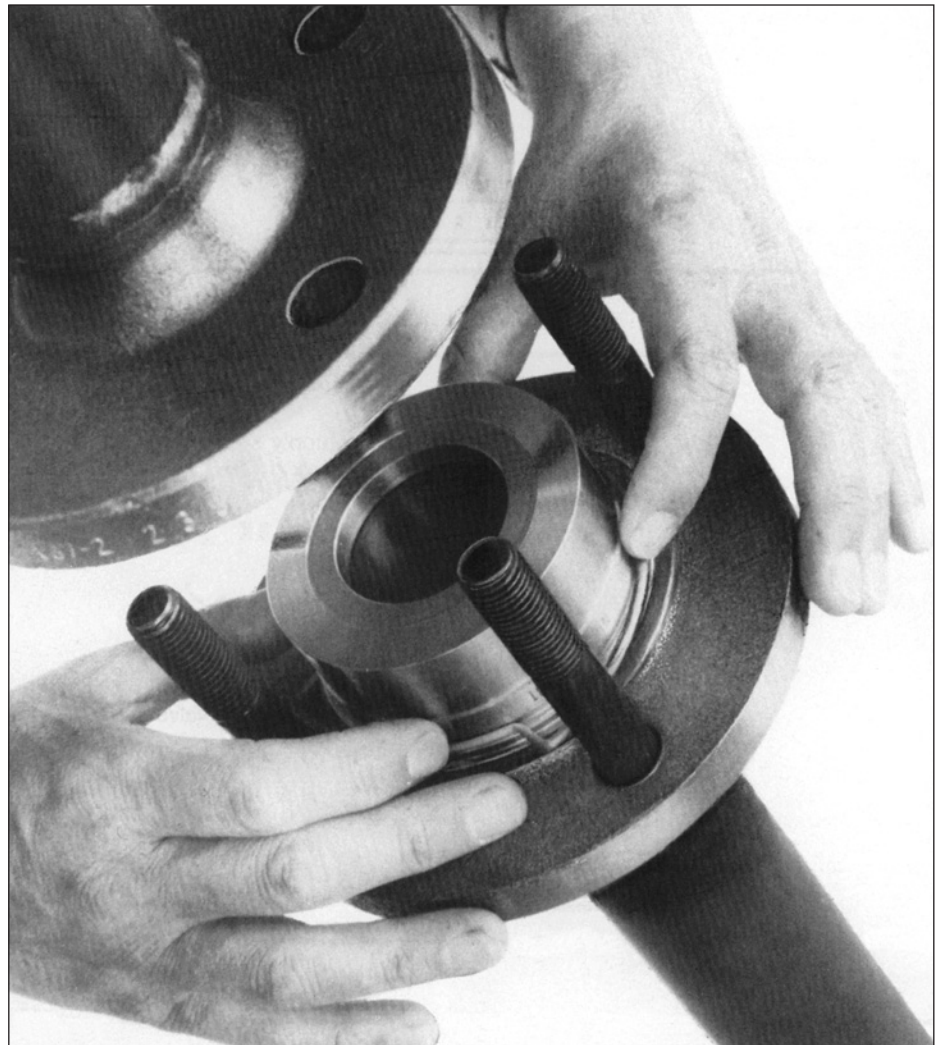

### Descriptions

Check valve, gravity circulation check valve, vacuum breaker valve, breather, foot valve.

### Applications

Heating and air-conditioning plants, steam and condensate systems, product and utility lines, marine installations.

### Fluids

Liquids, gases, vapours, aggressive media.

### Technical Data

Nominal pressure ratings PN 6 – 400 bar  
Nominal sizes (DN) 15 – 200 mm (½ – 8")  
Max. service pressure 400 barg  
Max. temperatures 550 °C  
Min. temperatures –200 °C

### Tightness

RK with metal-to-metal seat in accordance with leakage rate C/D to DIN EN 12266. For extreme conditions: valve disc/cone with soft seal made from EPDM or FPM according to leakage rate A to DIN EN 12266.

## Examples of Application

The following examples give only a few of the many applications. We shall be pleased to discuss any of your problems or requirements.

### RK in heating installations

**Fig. 1**

RK used with pumps mounted in parallel. In order to avoid reverse flow via the pump at rest, a non-return valve has to be installed after each pump.

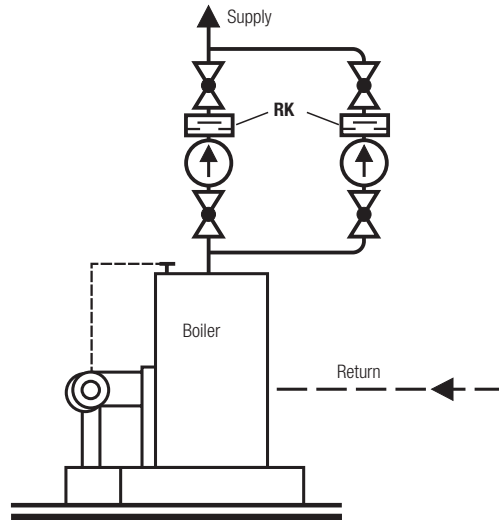
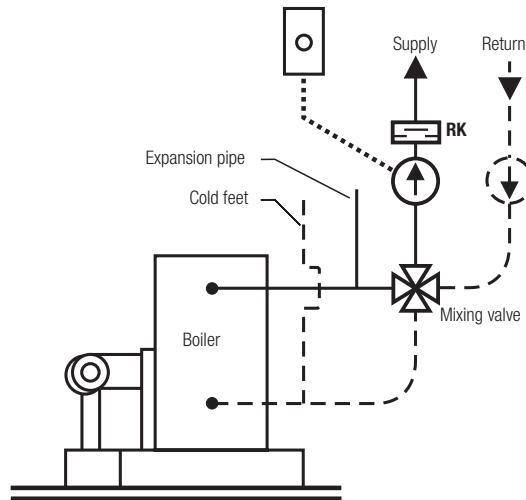

**Fig. 1**

**Fig. 2**

RK as gravity circulation check. The non-return valve is opened by the pump pressure. When the pump is turned off the RK is closed by the force of the integral spring, and gravity circulation is avoided. The pump is started and stopped by a room thermostat.

The mixing valve ensures that, after long periods of standstill, water at too low a temperature will not be returned to the boiler and cause corrosion.

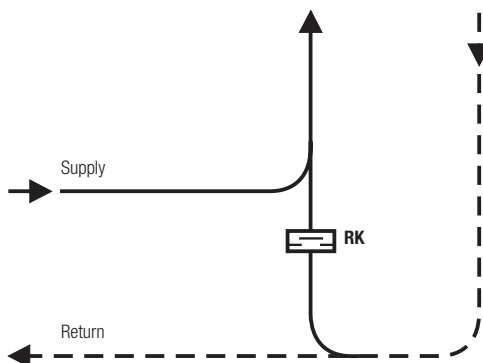

**Fig. 2**

**Fig. 3**

Use of RK to prevent the formation of a short-circuit. If a residence is directly connected to the circuit of a district heating plant operating with a high temperature differential (temperature difference between supply and return line of district heating system) the RK prevents a short-circuit between supply and return lines.

In some cases it might be advisable to install a throttling device upstream of the RK or to size the pipeline accordingly.



**Fig. 3**

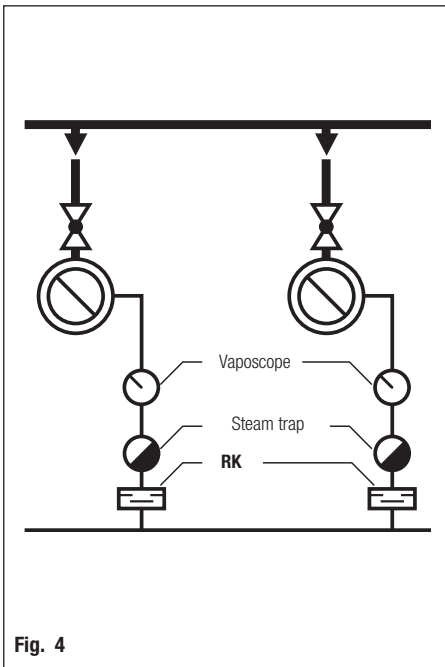

Fig. 4

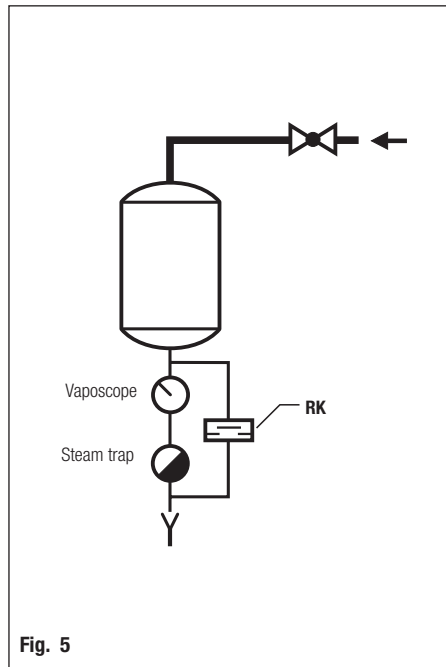

Fig. 5

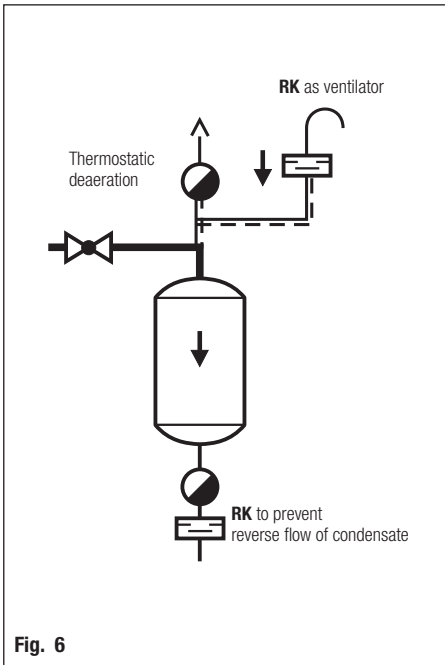

Fig. 6

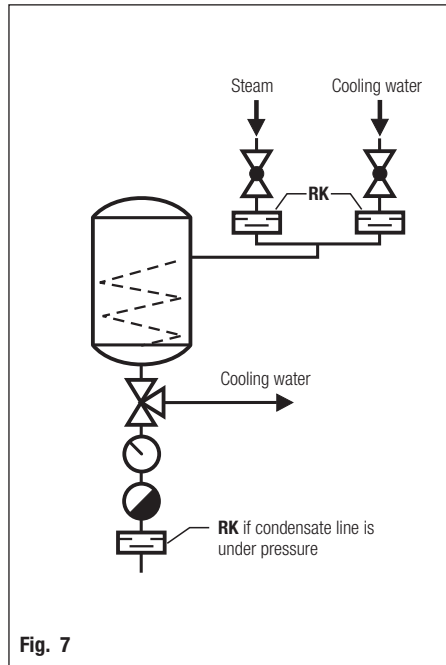

Fig. 7

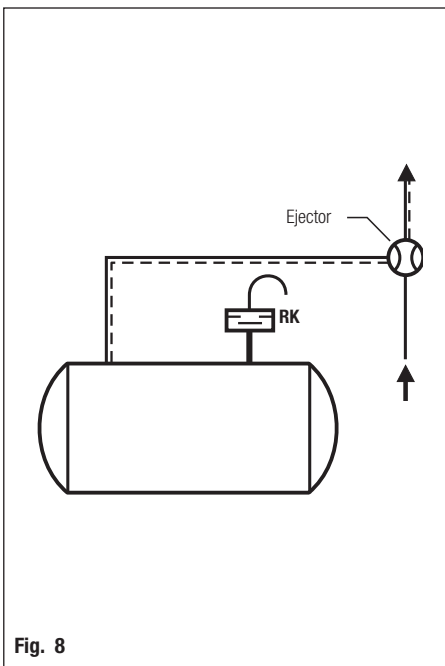

Fig. 8

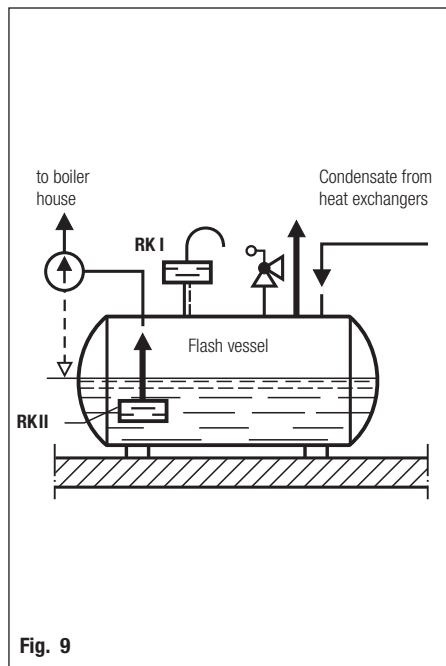

Fig. 9

## RK in steam and condensate systems

Fig. 4

Use of RK with heat exchangers mounted in parallel to prevent return of condensate. Moreover, the RK allows the repair or exchange of part of the installation without having to shut down the entire plant. It suffices to shut the isolating valve of the heat exchanger.

Fig. 5

RK mounted in bypass, with its direction of flow reverse to that of the trap. It will prevent a vacuum from building up in the heat exchanger if steam is shut off. The RK will open as soon as the pressure in the heat exchanger drops below that in the condensate line.

Fig. 6

RK as a vacuum breaker mounted in parallel with a thermostatic air vent in the inverse direction of flow. The RK will open as soon as the pressure in the heat exchanger drops below atmospheric pressure. The second RK prevents reverse flow of condensate and heating of the heat exchanger.

Fig. 7

Use of RK to protect against errors in operation. If one coil is used for both heating and cooling RK non-return valves should be installed after the inlet valves, so that in case both valves are opened in error steam cannot enter into the cooling water line nor cooling water into the steam line.

Fig. 8

RK as relief valve in vacuum installations. The non-return valve will open as soon as the vacuum pump, ejector, condenser or similar equipment fail and excess pressure starts building up.

Fig. 9

RK as a vacuum breaker and foot valve. The non-return valve RK I prevents the building-up of a vacuum in vessels and containers. The non-return valve RK II will prevent the suction tube from emptying if the pump is stopped.

## RK in land and marine installations

**Fig. 10**

Use of RK to prevent a pressure drop in pressure vessels if the pump is stopped.

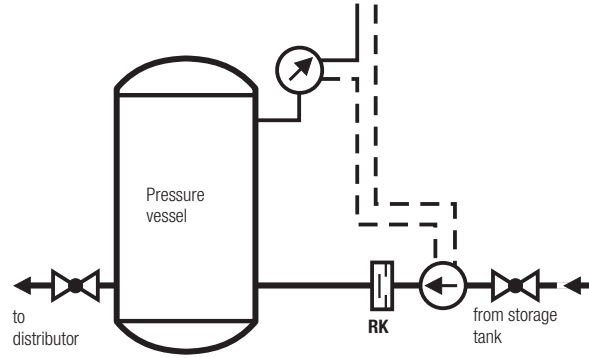

**Fig. 10**

**Fig. 11**

Use of RK to prevent return flow of the oil into the storage tank if the burner is switched off.

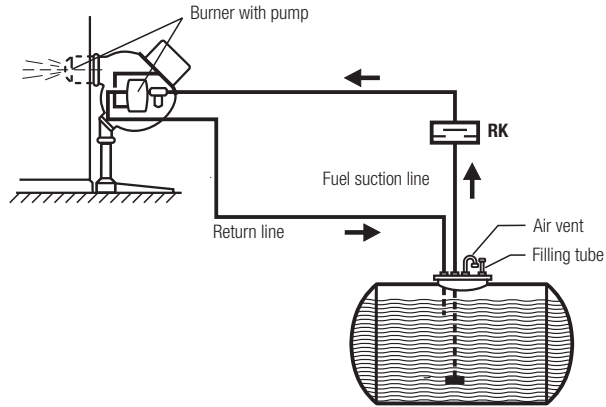

**Fig. 11**

**Fig. 12**

Use of RK to prevent pressure drop in the hydraulic control system or in the lubrication system of a turbine. The main oil pump I is directly driven by the turbine via gear wheels and forces the oil into the hydraulic control or the lubrication systems. If the pressure is too low the auxiliary pump II will be started by a pressure-controlled switch. If one pump is in operation, the non-return valves will prevent a drop in the oil pressure via the second pump.

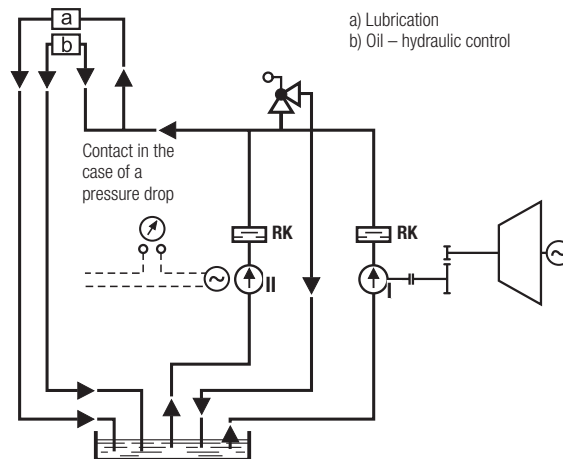

**Fig. 12**

# GESTRA AG

P. O. Box 10 54 60, D-28054 Bremen  
 Münchener Str. 77, D-28215 Bremen  
 Tel. 0049 (0) 421 35 03 - 0, Fax 0049 (0) 421 35 03-393  
 E-Mail gestra.ag@flowserve.com, Web www.gestra.de

# FLOWSERVE®

GESTRA